



TENDER NO. KP1/1/3A/4/1/OT/007/18-19
SUPPLY AND DELIVERY OF ROUTERS, FIBER OPTIC CABLES, TOOLS AND
ACCESSORIES

FEBRUARY 2019

ALL TENDERERS ARE ADVISED TO READ CAREFULLY THIS TENDER DOCUMENT IN ITS
ENTIRETY BEFORE MAKING ANY BID

TENDER DOCUMENT FOR SUPPLY OF GOODS
(OPEN TENDER)

THE KENYA POWER & LIGHTING COMPANY LIMITED
CENTRAL OFFICE, STIMA PLAZA,
KOLOBOT ROAD, PARKLANDS,
P.O. BOX 30099-00100,
NAIROBI,
KENYA.

Telephones: +254-020-3201000; 3644000 Pilot Lines

Telephones: +254 -720-600070/1-5; -733-755001/2-3 Cellular

Website: www.kplc.co.ke

Email 1: JNdinya@kplc.co.ke

2: AChondo@kplc.co.ke

3: _DKiniti@kplc.co.ke

Table of Contents

SECTION I - INVITATION TO TENDER	3
SECTION II - TENDER SUBMISSION CHECKLIST	4
SECTION III - INSTRUCTIONS TO TENDERERS	7
SECTION IV - SCHEDULE OF REQUIREMENTS	27
SECTION V - PRICE SCHEDULE FOR GOODS	32
SECTION VI - EVALUATION CRITERIA	38
SECTION VII – GENERAL CONDITIONS OF CONTRACT	43
SECTION VIII – SPECIAL CONDITIONS OF CONTRACT	55
SECTION X – CONFIDENTIAL BUSINESS QUESTIONNAIRE FORM	58
SECTION XI A - TENDER SECURITY FORM – (BANK GUARANTEE)	61
SECTION XI B - TENDER SECURITY FORM (SACCO SOCIETY, DEPOSIT TAKING MICRO FINANCE INSTITUTIONS, WOMEN ENTERPRISE FUND & YOUTH ENTERPRISE FUND)	63
SECTION XI C - TENDER SECURITY – (LETTERS OF CREDIT).....	66
SECTION XI A - MANUFACTURER’S AUTHORIZATION FORM	68
SECTION XI B - MANUFACTURER’S WARRANTY FORM.....	69
SECTION XIII - DECLARATION FORM	70
SECTION XIV – DRAFT LETTER OF NOTIFICATION OF AWARD	71
SECTION XV – DRAFT LETTER OF NOTIFICATION OF REGRET	72
SECTION XVI - CONTRACT AGREEMENT FORM	73
SECTION XVII A - PERFORMANCE SECURITY FORM (BANK GUARANTEE)	78
SECTION XVII B - PERFORMANCE SECURITY (LC)	80
SECTION XVIII – SUBCONTRACTORS	82
(INFORMATION TO BE PROVIDED BY THE TENDERER).....	82
SECTION XIX - PREVIOUS EXPERIENCE WITH SIMILAR WORK (INFORMATION TO BE PROVIDED BY THE TENDERER).....	83
SECTION XVIII - SUPPLIER EVALUATION FORM.....	84
SECTION XIX - THE TECHNICAL SPECIFICATIONS.....	87

SECTION I - INVITATION TO TENDER

DATE: FEBRUARY, 2019

TENDER NO. KP1/1/3A/4/1/OT/007/18-19 FOR SUPPLY AND DELIVERY OF ROUTERS, FIBER OPTIC CABLES, TOOLS AND ACCESSORIES.

1.1 The Kenya Power & Lighting Company Limited hereinafter referred to KPLC invites bids from eligible Tenderers for Supply and delivery Routers, Fiber Optic cables, tools and accessories. Interested eligible Tenderers may obtain further information from the General Manager, Supply Chain, KPLC at Stima Plaza, 3rd Floor, Kolobot Road, P.O. Box 30099 – 00100 Nairobi, Kenya.

1.2 Obtaining tender documents.

1.2.1 Tender documents detailing the requirements may be obtained from the KPLC E-Procurement Portal found on KPLC's website (www.kplc.co.ke) beginning on **Tuesday 26th February, 2019.**

1.3 Submission of Tender documents

Completed Tenders are to be saved as PDF document marked **TENDER NO. KP1/1/3A/4/1/OT/007/18-19 FOR SUPPLY AND DELIVERY OF ROUTERS, FIBER OPTIC CABLES, TOOLS AND ACCESSORIES** and submitted in electronic format on the KPLC's E-procurement portal on the due date and time published on the portal. Tenderers are required to visit the portal from time to time for revised closing dates and addendums. The Tender is to be submitted ONLINE on or before the submission date and time indicated on the KPLC tendering portal. i.e. **Monday 25th March, 2019 at 10.00am**. The submitted tenders shall be opened at **10.00am** on the same date in the **Lower Conference Room** located at **IESR Ruaraka near Utalii College** in the presence of the tenderer or their representatives who choose to attend.

1.4 Prices

Prices quoted should be inclusive of all taxes and delivery costs to the required site (where applicable) and must be in Kenya Shillings or a freely convertible currency in Kenya and shall remain valid for ninety (90) days from the closing date of the tender. *Please note that prices indicated on the KPLC tendering portal should be exclusive of VAT*

1.5 There will be no pre-bid meeting for this tender.

SECTION II - TENDER SUBMISSION CHECKLIST

Bidders are advised to clearly label their documents while uploading on the portal.

No.	Item	Tick Where Provided
1	Tender Security – Bank Guarantee or Letters of Credit (issued by Banks Licensed by the Central Bank of Kenya), Guarantee by a deposit taking Microfinance Institution, Sacco Society, the Youth Enterprise Development Fund or the Women Enterprise Fund.	
2	Declaration Form	
3	Duly completed Tender Form	
4	Copy of Company or Firm’s Registration Certificate	
5	Copy of PIN Certificate	
6	Copy of Valid Tax Compliance Certificate	
7	Confidential Business Questionnaire (CBQ)	
8	Certificate of Confirmation of Directors and Shareholding (C.R.12) for registered companies and if not a registered company a business name for those trading as a sole proprietor or a partnership registered under the Kenyan law or equivalent certification for foreign tenderers.	
9	Type Test Certificates and their Reports and or Test Certificates and their Reports	
10	Copy of accreditation certificate for the testing laboratory as per ISO/ IEC 17025,	
11	Valid and current ISO 9001 Certificates or for locally manufactured or produced goods, valid Mark of Quality Certificate or Standardization Mark Certificates from the Kenya Bureau of Standards (KEBS).	
12	Catalogues and or Manufacturer’s drawings	
13	Duly completed Schedule of Guaranteed Technical Particulars	
14	Manufacturer’s Authorization	
15	Manufacturer’s Warranty Form	
16	Names with full contact as well as physical addresses of previous customers of similar goods and reference letters from at least four (4) previous customers	
17	Statement on Deviations	

18	Price Schedule(s)	
19	Schedule of requirements duly filled indicating items offered	
20	Financial Statements. The audited financial statements required must be those that are reported within eighteen (18) calendar months of the date of the tender document. <i>(For companies or firms that are registered or incorporated within the last one calendar year of the Date of the Tender Document, they should submit certified copies of bank statements covering a period of at least six months prior to the date of the tender document. The copies should be certified by the Bank issuing the statements. The certification should be original).</i>	
21	Any other document or item required by the Tender Document. (The Tenderer shall specify such other documents or items it has submitted)	
22	Samples if required	

***NOTES TO TENDERERS**

1. Valid Tax Compliance Certificate shall be one issued by the relevant tax authorities and valid for at least up to the tender closing date. All Kenyan registered Tenderers must provide a valid Tax Compliance Certificate.
2. All Kenyan registered Tenderers must provide the Personal Identification Number Certificate (PIN Certificate).
3. Foreign Tenderers must provide equivalent documents from their country of origin as regards Tax Compliance and PIN certificates OR statements certifying that the equivalent documentation is not issued in the Tenderer's country of origin. The Statement(s) that equivalent documentation is not issued by the Tenderer's country should be original and issued by the Tax authorities in the Tenderer's country of origin.

TABLE OF PARAGRAPHS ON INSTRUCTIONS TO TENDERERS

PARAGRAPH NO.	HEADINGS	PAGE NO.
3.1	DEFINITIONS...	8
3.2	ELIGIBLE TENDERERS...	9
3.3	ELIGIBLE GOODS.....	10
3.4	COST OF TENDERING.....	11
3.5	CONTENTS OF THE TENDER DOCUMENT...	11
3.6	CLARIFICATION OF DOCUMENTS...	12
3.7	AMENDMENT OF DOCUMENTS...	12
3.8	LANGUAGE OF TENDER.....	12
3.9	DOCUMENTS COMPRISING THE TENDER.....	12
3.10	TENDER FORM.....	13
3.11	TENDER PRICES.....	13
3.12	TENDER CURRENCIES...	14
3.13	TENDERER'S ELIGIBILITY AND QUALIFICATIONS.....	14
3.14	GOODS ELIGIBILITY AND CONFORMITY TO TENDER DOCUMENTS.....	15
3.15	SAMPLE(S).....	16
3.16	WARRANTY.....	16
3.17	TENDER SECURITY.....	17
3.18	VALIDITY OF TENDERS.....	18
3.19	ALTERNATIVE OFFERS.....	19
3.20	PREPARATION AND SIGNING OF THE TENDER...	19
3.21	DEADLINE FOR SUBMISSION OF TENDER.....	19
3.22	MODIFICATION AND WITHDRAWAL OF TENDERS...	20
3.23	OPENING OF TENDERS.....	20
3.24	PROCESS TO BE CONFIDENTIAL.....	20
3.25	CLARIFICATION OF TENDERS AND CONTACTING KPLC.....	21
3.26	PRELIMINARY TENDER EVALUATION.....	21
3.27	MINOR DEVIATIONS, ERRORS OR OVERSIGHTS...	21
3.28	TECHNICAL EVALUATION OF TENDERS...	22
3.29	FINANCIAL EVALUATION OF TENDERS...	22
3.30	PREFERENCES.....	22
3.31	DEBARMENT OF A TENDERER.....	23
3.32	CONFIRMATION OF QUALIFICATION FOR AWARD.....	23
3.33	AWARD OF CONTRACT...	23
3.34	TERMINATION OF PROCUREMENT PROCEEDINGS.....	23
3.35	NOTIFICATION OF AWARD.....	24
3.36	SIGNING OF CONTRACT.....	24
3.37	PERFORMANCE SECURITY.....	25
3.38	CORRUPT OR FRAUDULENT PRACTICES...	26

SECTION III - INSTRUCTIONS TO TENDERERS

3.1 Definitions

In this tender, unless the context or express provision otherwise requires: -

- a) *Any reference to any Act shall include any statutory extension, amendment, modification, re-amendment or replacement of such Act and any rule, regulation or order made there-under.*
- b) *“Date of Tender Document” shall be the **start date** specified on the KPLC tendering portal.*
- c) *“Day” means calendar day and “month” means calendar month.*
- d) *“KEBS” wherever appearing means the Kenya Bureau of Standards or its successor(s) and assign(s) where the context so admits.*
- e) *“KENAS” wherever appearing means the Kenya National Accreditation Service or its successor(s) and assign(s) where the context so admits*
- f) *“PPRA” wherever appearing means The Public Procurement Regulatory Authority or its successor(s) and assign(s) where the context so admits.*
- g) *Reference to “the tender” or the “Tender Document” includes its appendices and documents mentioned hereunder and any reference to this tender or to any other document includes a reference to the other document as varied supplemented and/or replaced in any manner from time to time.*
- h) *“The Procuring Entity” means The Kenya Power and Lighting Company Limited or its successor(s) and assign(s) where the context so admits (hereinafter abbreviated as KPLC).*

- i) *“The Tenderer” means the person(s) submitting its Tender for the supply, installation and commissioning (where applicable) of the goods in response to the Invitation to Tender.*
- j) *Where there are two or more persons included in the expression the “Tenderer”, any act or default or omission by the Tenderer shall be deemed to be an act, default or omission by any one or more of such persons.*
- k) *Words importing the masculine gender only, include the feminine gender or (as the case may be) the neutral gender.*
- l) *Words importing the singular number only include the plural number and vice-versa and where there are two or more persons included in the expression the “Tenderer” the covenants, agreements and obligations expressed to be made or performed by the Tenderer shall be deemed to be made or performed by such persons jointly and severally.*

- m) *KPLC’s “authorized person” shall mean its MD & CEO who is designated by the PPAD Act 2015 to exercise such power, authority or discretion as is required under the tender and any contract arising therefrom, or such other KPLC staff delegated with such authority.*
- n) *Citizen contractors-a firm shall be qualified as a citizen contractor if its owners and shareholders are Kenyan citizens*
- o) *Local contractors- a firm shall be qualified as a local contractor if it is registered in Kenya.*

3.2 Eligible Tenderers

3.2.1 A tenderer is eligible to bid for this contract only if the tenderer satisfies the following criteria—

- (a) the tenderer has the legal capacity to enter into a contract for procurement or asset disposal;*
- (b) the tenderer is not insolvent, in receivership, bankrupt or in the process of being wound up;*
- (c) the tenderer, if a member of a regulated profession, has satisfied all the professional requirements;*
- (d) the tenderer and his or her sub-contractor, if any, is not debarred;*
- (e) the tenderer has fulfilled tax obligations;*
- (f) the tenderer has not been convicted of corrupt or fraudulent practices;*
- and*
- (g) is not guilty of any serious violation of fair employment laws and practices.*

In addition, this Invitation to Tender is open to all Tenderers eligible as described in the

Appendix to Instructions to Tenderers.

Successful Tenderers shall supply the goods in accordance with this tender and the ensuing contract.

- 3.2.2 Collusion or Agreements between eligible tenderers to directly or indirectly fix prices or any other trading conditions is prohibited. Where this is discovered, the tenderers involved will not be eligible for award and shall be disqualified.
- 3.2.3 Notwithstanding any other provisions of this tender, the following are not eligible to participate in the tender:-
- a) KPLC's employees, its Board or any of its committee members.
 - b) Any Public/State Officer of the Government of the Republic of Kenya (GoK).
 - c) Any member of a Board or Committee or any department of GoK.
 - d) Any person appointed to any position by the President of Kenya.
 - e) Any person appointed to any position by any Cabinet Secretary of GoK.
 - f) Any tenderer submitting false, inaccurate or incomplete information about their qualifications.
- 3.2.4 In addition the tenderer shall be considered ineligible to bid, where in case of a corporation, private company, partnership or other body, the tenderer, their spouse, child or sub-contractor has substantial or controlling interest and is found to be in contravention of the provisions of section 3.2.1 above.
- 3.2.5 Despite the provisions of section 3.2.3 and 3.2.4, a tenderer having a substantial or controlling interest shall be eligible to bid where—
- (a) such tenderer has declared any conflict of interest; and
 - (b) performance and price competition for that good, work or service is not available or can only be sourced from that tenderer.
- 3.2.6 For the purposes of this paragraph, any relative i.e. spouse(s) and child(ren) of any person mentioned in sub-paragraph 3.2.3 is also ineligible to participate in the tender. In addition, a Cabinet Secretary shall include the President, Deputy President or the Attorney General of GoK.
- 3.2.7 Tenderers shall provide the qualification information statement that the Tenderer (including subcontractors) is not associated, or have been associated in the past, directly or indirectly, with a firm or any of its affiliates which have been engaged by KPLC to provide consulting services for the preparation of the design, specifications, and other documents to be used for the procurement of the goods under this Invitation to Tender.
- 3.2.8 Tenderers shall not be under declarations as prescribed at Section XIII.
- 3.2.9 Tenderers who are not under these declarations shall complete the Declaration Form strictly in the form and content as prescribed at Section XIII.

3.2.10 Those that are under the Declaration as prescribed at Section XIII whether currently or in the past shall not complete the Form. They will submit a suitable Form giving details, the nature and present status of their circumstances.

3.3 Eligible Goods

3.3.1 All goods to be supplied under the contract shall have their origin in eligible source countries. These countries are as described in the Appendix to Instructions to Tenderers.

3.3.2 For purposes of this clause, “origin” means the place where the goods are mined, grown, or produced. Goods are produced when, through manufacturing, processing, or substantial and major assembly of components, a commercially recognized product results that is substantially different in basic characteristics or in purpose or utility from its components.

3.3.3 The origin of goods is distinct from the nationality of the Tenderer.

3.4 Cost of Tendering

3.4.1 The Tenderer shall bear all costs associated with the preparation and submission of its Tender, and KPLC will in no case be responsible or liable for those costs, regardless of the conduct or outcome of the tendering process.

3.5 Contents of the Tender Document

3.5.1 The Tender Document comprises the documents listed below and Addendum (where applicable) issued in accordance with paragraph 3.7 of these Instructions to Tenderers: -

- a) *Invitation to Tender*
- b) *Tender Submission Checklist*
- c) *Instructions to Tenderers*
- d) *Appendix to Instructions to Tenderers*
- e) *Schedule of Requirements*
- f) *Delivery Schedule*
- g) *Price Schedule for Goods*
- h) *Evaluation Criteria*
- i) *General Conditions of Contract*
- j) *Special Conditions of Contract*
- k) *Tender Form*
- l) *Confidential Business Questionnaire Form*
- m) *Tender Security Form*
- n) *Manufacturer’s Authorization Form*
- o) *Manufacturer’s Warranty*
- p) *Declaration Form*
- q) *Contract Form*

- r) *Performance Security Form*
- s) *Technical Specifications*
 - (i) *General Requirements*
 - (ii.) *Detailed Technical Specifications*

3.5.2 The Tenderer is expected to examine all instructions, forms, provisions, terms and specifications in the Tender Document. Failure to furnish all information required by the Tender Document or to submit a tender not substantially responsive to the Tender Document in every respect will be at the Tenderer’s risk and may result in the rejection of its Tender.

3.5.3 All recipients of the documents for the proposed Contract for the purpose of submitting a tender (*whether they submit a tender or not*) shall treat the details of the documents as “Private and Confidential”.

3.6 Clarification of Documents

A prospective Tenderer requiring any clarification of the Tender Document may notify the General Manager Supply Chain in writing and ensure receipt is acknowledged at KPLC’s Physical address indicated on the Tender Document. KPLC will respond in writing to any request for clarification of the Tender documents, which it receives not later than seven (7) days prior to the deadline for the submission of Tenders, prescribed by KPLC. Written copies of KPLC’s response (*including an explanation of the query but without identifying the source of inquiry*) will be published and accessible to all prospective Tenderers on the KPLC’s tendering portal.

3.7 Amendment of Documents

3.7.1 At any time prior to the deadline for submission of Tenders, KPLC, for any reason, whether at its own initiative or in response to a clarification requested by a prospective Tenderer, may modify the tender documents by amendment.

3.7.2 All prospective Tenderers that have registered in the portal for the Tender will be notified of the amendment(s) (*hereinafter referred to or otherwise known as addendum*) in writing and will be binding on them.

3.7.3 In order to allow prospective Tenderers reasonable time in which to take the amendment into account in preparing their Tenders, KPLC, at its discretion, may extend the deadline for the submission of Tenders.

3.8 Language of Tender

The Tender prepared by the Tenderer, as well as all correspondence and documents relating to the tender, exchanged between the Tenderer and KPLC, shall be written in English language. Any printed literature furnished by the

Tenderer written in any other language shall be accompanied by an accurate English translation of the relevant passages, in which case, for purposes of interpretation of the Tender, the English translation shall govern. The English translation shall be on the Tenderer's letterhead and shall be signed by the duly authorized signatory signing the Tender and stamped with the Tenderer's stamp.

3.9 Documents Comprising the Tender

The Tender prepared and submitted by the Tenderer shall include but not be limited to all the following components: -

- a) *Declaration Form, Tender Form and a Price Schedule completed in compliance with paragraphs 3.2, 3.10, 3.11 and 3.12.*
- b) *Documentary evidence established in accordance with paragraph 3.13 that the Tenderer is eligible to tender and is qualified to perform the contract if its tender is accepted.*
- c) *Documentary evidence established in accordance with paragraph 3.14 that the goods and ancillary services to be supplied by the Tenderer are eligible goods and services and conform to the tender documents, and,*
- d) *Tender Security furnished in accordance with paragraph 3.17*
- e) *A detailed list of previous customers as prescribed for similar items on tender and their contact addresses shall be submitted with the Tender for the purpose of reference, or for evaluation where the technical specifications so dictate.*
- f) *And all other documents indicated in Section II (Tender Submission Checklist)*

3.10 Tender Form

- 3.10.1 The Tenderer shall complete and sign the Tender Form and all other documents furnished in the Tender Document, indicating the goods to be supplied, a brief description of the goods, their country of origin, quantity, and prices amongst other information required.
- 3.10.2 If the Form is found to have insufficient space to fit all of the Tenderer's information, data, etc., the Tenderer shall attach a sheet or sheets immediately after such page clearly labeling at the top of each page of such attachment with the title of that Form and numbering accordingly.

3.11 Tender Prices

- 3.11.1 The Tenderer shall indicate on the appropriate Price Schedule, the unit prices and total tender price of the goods it proposes to supply under the contract.
- 3.11.2 Prices indicated on the Price Schedule shall include all costs including taxes, insurances and delivery to the premises (where applicable) of KPLC or other specified site.

- 3.11.3. For the avoidance of doubt, Tenderers shall quote on Delivered Duty Paid (*DDP*) basis. No other basis shall be accepted for evaluation, award or otherwise.
- 3.11.4 Section 20 of the Insurance Act Cap.487 requires all imports to the country to be insured with a local insurance company. It is now mandatory for all marine cargo imports to adhere to this requirement
- 3.11.5 Tender prices to be submitted (quoted) by the Tenderer shall remain fixed for the contract duration.

3.12 Tender Currencies

- 3.12.1 For goods that the Tenderer will supply from within or outside Kenya, the prices shall be quoted in Kenya Shillings, or in another freely convertible currency in Kenya. The currency quoted must be indicated clearly on the Price Schedule of Goods.
- 3.12.2 The exchange rate to be used for currency conversion for evaluation purposes shall be the Central Bank of Kenya selling rate prevailing on the Tender closing date. (Please visit the Central Bank of Kenya website).

3.13 Tenderer's Eligibility and Qualifications

- 3.13.1 Pursuant to paragraph 3.2, the Tenderer shall furnish, as part of its Tender, documents establishing the Tenderer's eligibility to tender and its qualifications to perform the contract if its Tender is accepted.
- 3.13.2 The documentary evidence of the Tenderer's eligibility to tender shall establish to KPLC's satisfaction that the Tenderer, at the time of submission of its Tender, is from an eligible source country as defined under paragraph 3.2
- 3.13.3 The documentary evidence of the Tenderer's qualifications to perform the contract if its Tender is accepted shall be established to KPLC's satisfaction –
 - a) *that, in the case of a Tenderer offering to supply goods under the contract which the Tenderer did not manufacture or otherwise produce, the Tenderer has been duly authorized by the goods' manufacturer or producer to supply the goods. The authorization shall strictly be in the form and content as prescribed in the Manufacturer's Authorization Form in the Tender Document.*
 - b) *That the Tenderer has the financial capability necessary to perform the contract. The Tenderer shall be required to provide the documents as specified in the Appendix to Instructions to Tenderers including a current Tax Compliance Certificate issued by the relevant tax authorities.*
 - c) *That the Tenderer has the technical and production capability necessary to perform the contract.*

d) *that, in the case of a Tenderer not doing business within Kenya, the Tenderer is or will be (if awarded the contract) represented by an agent in Kenya equipped and able to carry out the Tenderer's maintenance, repair, spare parts and stocking obligations prescribed in the Conditions of Contract and or in the Technical Specifications.*

3.13.4 Tenderers with any record of unsatisfactory or default in performance obligations in any contract shall not be considered for evaluation, award or otherwise. For the avoidance of doubt, this shall include any tenderer with unresolved case(s) in its performance obligations for more than two (2) months in any contract.

3.14 Goods Eligibility and Conformity to Tender Documents

3.14.1 Pursuant to paragraph 3.3 of this Section, the Tenderer shall furnish, as part of its tender, documents establishing the eligibility and conformity to the Tender Document of all goods that the Tenderer proposes to supply under the contract.

3.14.2 The documentary evidence of the eligibility of the goods shall consist of a statement in the Price Schedule of the country of origin of the goods and services offered which shall be confirmed by a certificate of origin issued at the time of shipment.

3.14.3 The documentary evidence of conformity of the goods to the Tender Document may be in the form of literature, drawings and data, and shall consist of: -

- a) *a detailed description of the essential technical and performance characteristics of the goods whether in brochures, catalogues, drawings or otherwise,*
- b) *a list giving full particulars, including available source and current prices of spare parts, special tools and other incidental apparatus necessary for the proper and continuing functioning of the goods for a minimum period of two (2) years, following commencement of the use of the goods by KPLC, and,*
- c) *Duly completed Schedule of Guaranteed Technical Particulars (GTP) as per Tender Specifications demonstrating substantial responsiveness of the goods and service to those specifications and, if any, a statement of deviations and exceptions to the provisions of the Technical Specifications.*

For (a), (b) and (c) above, the literature, drawings and data shall be those from the Manufacturer.

3.14.4 For goods from outside Kenya, the Tenderer shall be required to demonstrate that the goods or products conform to required standards by evidence of:

- a) A Type Test Certificate and its Reports issued by a third party testing laboratory accredited to ISO/IEC 17025.
- b) Where (a) above is not required in the tender specifications, a Test Certificate and its Reports issued by the National Testing or Standards Authority of the country of manufacture or production.

- c) The Type Test Certificates, Type Test Reports, Test Certificates and Test Reports shall NOT be more than five years old.
- 3.14.5 For goods manufactured or produced in Kenya, the Tenderer shall be required to demonstrate that the goods conform to required standards and specifications by evidence of:–
- a) A Type Test Certificate and its Reports issued by KEBS.
 - b) Where (a) above is not required in the tender specifications, a Test Certificate and its Reports issued by KEBS or any Testing Authority approved by KEBS or accredited by KENAS.
 - c) The Type Test Certificates, Type Test Reports, Test Certificates and Test Reports shall NOT be more than five years old.
- 3.14.6 For both paragraphs 3.14.4 and 3.14.5, the Tenderer shall submit with its Tender a copy of the accreditation certificate for the testing body. KPLC reserves the right to subject the certificate to authentication.
- 3.14.7 Additional evidence of conformity of the goods to the Tender Document shall include sample(s) where required.
- 3.14.8 For purposes of the documentary and other evidence to be furnished pursuant to subparagraphs 3.14.3, 3.14.4 and 3.14.5 above, the Tenderer shall note that standards for workmanship, material, and equipment, as well as references to brand names or catalogue numbers designated by KPLC in its Technical Specifications, are intended to be descriptive only and not restrictive. The Tenderer may adopt higher standards, brand names, and or catalogue numbers in its Tender, provided that it demonstrates to KPLC's satisfaction that the substitutions ensure substantial equivalence to those designated in the Technical Specifications.

3.15 Sample(s)

- 3.15.1 Where required in the Appendix to Instruction to Tenderers, all Tenderers must also submit sample(s) in conformity with the technical specifications securely and clearly labelled with -
- a) *the Tender number and name,*
 - b) *the opening date and time of the tender,*
 - c) *the name or identity of the sample, and,*
 - d) *the name of the Tenderer.*
- 3.15.2 The sample(s) shall be considered as part of the tender and must be submitted on or before the deadline for submission of Tenders and receipt acknowledged by KPLC evidenced by a stamped delivery note.

3.16 Warranty

- 3.16.1 All Tenderers must provide a Warranty that warrants that the goods to be supplied under the contract are new, unused, of the most recent or current specification and incorporate all recent improvements in design and materials unless provided otherwise in the Tender. The Warranty shall also warrant that the goods in the Tenderer's bid have no defect arising from manufacture, materials or workmanship or from any act or omission of the Tenderer that may develop under normal use of the goods under the conditions obtaining in Kenya.
- 3.16.2 This warranty will remain valid for the period indicated in the special conditions of contract after the goods, or any portion thereof as the case may be, have been delivered to the final destination indicated in the contract.

3.17 Tender Security

- 3.17.1 The Tenderer shall furnish, as part of its Tender, a tender security for the amount specified in the Appendix to Instructions to Tenderers. The Original Tender Security, in a clearly labelled envelop, shall be deposited in the Tender Security Box on 3rd floor Stima Plaza on or before the opening date and time and receipt acknowledged by KPLC evidenced by a stamped copy
- 3.17.2 The tender security shall be either one or a combination of the following:-
- a) an original Bank Guarantee that is strictly in the form and content as prescribed in the Tender Security Form (Bank Guarantee) in the Tender Document.
 - b) For Local bidders, Standby Letters of Credit (LC). All costs, expenses and charges levied by all banks party to the LC shall be prepaid/borne by the Tenderer. The LC must contain all the mandatory conditions of payment to KPLC as prescribed in the Tender Security (Letters of Credit) provided in the Tender Document.
 - c) For Foreign bidders, Standby Letters of Credit (LC) confirmed by a bank in Kenya. All costs, expenses and charges levied by all banks party to the LC including confirmation charges shall be prepaid/borne by the Tenderer. The LC must contain all the mandatory conditions of payment to KPLC as prescribed in the Tender Security (Letters of Credit) provided in the Tender Document.
 - d) An original Guarantee by a deposit taking Microfinance Institution, Sacco Society, Youth Enterprise Development Fund or the Women Enterprise Fund, that is strictly in the form and content as prescribed in the Tender Security Form
- 3.17.3 The tender security is required to protect KPLC against the risk of the Tenderer's conduct which would warrant the security's forfeiture pursuant to paragraph 3.17.10.
- 3.17.4 The Tender Security shall be denominated in Kenya Shillings or in another freely convertible currency in Kenya. A Tender Security in form of a Bank Guarantee or

a Standby Letter of Credit issued on behalf of local bidders, should be from a commercial bank licensed by the Central Bank of Kenya. A Tender Security in form of a Standby Letter of Credit issued on behalf of foreign bidders by foreign banks, should be confirmed by a commercial bank licensed by the Central Bank of Kenya.

- 3.17.5 The Tender Security shall be valid for thirty (30) days beyond the validity of the tender.
- 3.17.6 KPLC shall seek authentication of the Tender Security from the issuing bank. It is the responsibility of the Tenderer to sensitize its issuing bank on the need to respond directly and expeditiously to queries from KPLC. The period for response shall not exceed five (5) days from the date of KPLC's query. Should there be no conclusive response by the bank within this period, such Tenderer's Tender Security may be deemed as invalid and the bid rejected.
- 3.17.7 Any Tender not secured in accordance with this paragraph will be rejected by KPLC as non-responsive, pursuant to paragraph 3.28.
- 3.17.8 The unsuccessful Tenderer's Tender Security will be released as promptly as possible, in any of the following circumstances: -
- a) *the procurement proceedings are terminated*
 - b) *KPLC determines that none of the submitted Tenders is responsive*
 - c) *a contract for the procurement is entered into.*
- 3.17.9 The successful Tenderer's Tender Security will be released upon the successful Tenderer's signing the contract, pursuant to paragraph 3.37 and furnishing an authentic Performance Security, pursuant to paragraph 3.38.
- 3.17.10 The Tender Security shall be forfeited –
- a) *if the Tenderer withdraws its Tender after the deadline for submitting Tenders but before the expiry of the period during which the Tenders must remain valid*
 - b) *if the Tenderer fails to enter into a written contract in accordance with paragraph 3.34*
 - c) *if the successful Tenderer fails to furnish the performance security in accordance with paragraph 3.38*
 - d) *if the Tenderer fails to extend the validity of the tender security where KPLC has extended the tender validity period in accordance with paragraph 3.18.*

3.18 Validity of Tenders

- 3.18.1 Tenders shall remain valid for ninety (90) days after the date of tender opening as specified in the Invitation to Tender or as otherwise may be prescribed by KPLC, pursuant to paragraph 3.22. A Tender that is valid for a shorter period shall be rejected by KPLC as non-responsive.
- 3.18.2 In exceptional circumstances, KPLC may extend the Tender validity period. The extension shall be made in writing. The tender security provided under paragraph 3.17 shall also be extended. A Tenderer shall not be required nor permitted to modify its tender during the extended period.

3.19 Alternative Offers

Only main offers shall be considered, as alternative offers are not acceptable.

3.20 Preparation and Signing of the Tender

- 3.20.1 The Tender shall be typed or written in indelible ink. It shall be signed by the Tenderer or a person or persons duly authorized to bind the Tenderer to the contract.
- 3.20.2 The authorization shall be indicated by a written Power of Attorney granted by the Tenderer to the authorized person before any of the following persons:-
- a) *For local Tenderers, a Commissioner of Oaths or a Notary Public or a Magistrate of the Kenyan Judiciary.*
 - b) *For foreign Tenderers, a Notary Public in the country of the Tenderer.*
- In either case above, the Power of Attorney shall accompany the Tender.
- 3.20.3 All pages of the Tender, including un-amended printed literature, shall be initialed by the person or persons signing the Tender and serially numbered.
- 3.20.4 The Tender shall have no interlineations, erasures, or overwriting except as necessary to correct errors made by the Tenderer, in which case such corrections shall be initialed by the person or persons signing the Tender.
- 3.20.5 KPLC will assume no responsibility whatsoever for the Tenderer's failure to comply with or observe the entire contents of this paragraph 3.20.
- 3.20.6 Any Tender not prepared and signed in accordance with this paragraph may be rejected by KPLC as non-responsive, pursuant to paragraph 3.26.

3.21 Deadline for Submission of Tenders

- 3.21.1 Tenders must be received by KPLC by the date and time specified in KPLC's tendering portal in PDF form.
- 3.21.2 KPLC may, at its discretion, extend this deadline for submission of Tenders by amending the tender documents in accordance with paragraph 3.7, in which case all rights and obligations of KPLC and the Tenderer previously subject to the initial deadline, will therefore be subject to the deadline as extended.

3.22 Modification and Withdrawal of Tenders

- 3.22.1 The Tenderer may modify or withdraw its Tender after it has submitted, provided that the modification, including substitution or withdrawal of the Tender is received by KPLC prior to the deadline prescribed for submission of tenders.
- 3.22.2 No Tender may be modified after the deadline for submission of Tenders.
- 3.22.3 No Tender may be withdrawn in the interval between the deadline for submission of tenders and the expiration of the period during which the Tender must remain valid except where KPLC extends the initial validity period. Any withdrawal of a Tender during this interval shall result in forfeiture of the Tenderer's Tender Security except where KPLC extends the initial validity period.

3.23 Opening of Tenders

- 3.23.1 KPLC shall open all Tenders promptly at the date and time specified in the KPLC tendering portal and at the location specified in the Invitation to Tender or as may otherwise be indicated.
- 3.23.2 The Tenderer's names, tender modifications or withdrawals, the presence or absence of requisite Tender Security and such other details as KPLC, at its discretion, may consider appropriate, will be announced at the opening.
- 3.23.3 At the Tender opening, tender prices, discounts, and such other details as KPLC, at its discretion, may consider appropriate will be read out.
- 3.23.4 The Tenderers or their representatives may attend the opening and those present shall sign a register evidencing their attendance.

3.24 Process to be Confidential

- 3.24.1 After the opening of tenders, information relating to the examination, clarification, evaluation and comparisons of tenders and recommendations arising there-from shall not be disclosed to a Tenderer or other person(s) not officially concerned with such process until conclusion of that process.
- 3.24.2 Conclusion of that process shall be deemed to have occurred, at the latest, by the date and time KPLC notifies the successful bidder(s). In any event, official disclosure by KPLC of any information upon conclusion of that process may only be to the unsuccessful bidders and may contain only the information permissible by law in summary form.
- 3.24.3 Any effort by a Tenderer to influence KPLC or any of its staff members in the process of examination, evaluation and comparison of tenders and information or decisions concerning the Tender may result in the disqualification of the Tenderer.

3.25 Clarification of Tenders and Contacting KPLC

- 3.25.1 To assist in the examination, evaluation and comparison of Tenders KPLC may, at its discretion, ask the Tenderer for a clarification of its Tender. The request for clarification and the response shall be in writing, and no change in the prices or substance of the Tender shall be sought, offered, or permitted.
- 3.25.2 The Tenderer is required to provide timely clarification or substantiation of the information that is essential for effective evaluation of its qualifications. It is the responsibility of the Tenderer to provide in writing the clarification or substantiation which should reach KPLC within five (5) days from the date of KPLC's query. Such writing may include by electronic mail or postal mail. Should there be no conclusive response within this period, it shall result in the Tenderer's disqualification.
- 3.25.3 Save as is provided in this paragraph and paragraph 3.6 above, no Tenderer shall contact KPLC on any matter related to its Tender, from the time of the tender opening to the time the successful Tenderer is announced.
- 3.25.4 Any effort by a Tenderer to influence KPLC in its decisions on tender evaluation, tender comparison, tender recommendation(s) or signing of Agreement may result in the disqualification of the Tenderer.

3.26 Preliminary Tender Evaluation

- 3.26.1 Prior to the detailed Technical and Financial evaluation, KPLC will determine the substantial responsiveness of each Tender. For purposes of this tender, a substantially responsive Tender is one that conforms to the requirements of Preliminary Evaluation. KPLC's determination of a Tender's responsiveness is to be based on the contents of the Tender itself without recourse to extrinsic evidence.
- 3.26.2 KPLC will examine the Tenders to determine whether they conform to the Preliminary Evaluation Criteria set out in the Section VI Evaluation Criteria.
- 3.26.3 Notwithstanding the contents of the foregoing sub-paragraphs, if a Tender is not substantially responsive, it will be rejected at the earliest stage of evaluation by KPLC and cannot subsequently be made responsive by the Tenderer by correction of any non-conformity.

3.27 Minor Deviations, Errors or Oversights

- 3.27.1 KPLC may waive any minor deviation in a Tender that does not materially depart from the requirements of the goods and or services set out in the Tender Document.
- 3.27.2 Such minor deviation -

- 3.27.2.1 shall be quantified to the extent possible,*
- 3.27.2.2 shall be taken into account in the evaluation process, and,*
- 3.27.2.3 Shall be applied uniformly and consistently to all qualified Tenders duly received by KPLC.*

3.27.3 KPLC may waive errors and oversights that can be corrected without affecting the substance of the Tender.

3.28 Technical Evaluation of Tenders

KPLC will evaluate and compare the Tenders that have been determined to be substantially responsive in compliance to the Technical requirements set out in the Tender Document.

3.29 Financial Evaluation of Tenders

- 3.29.1 Upon completion of the preliminary and technical evaluation, KPLC shall conduct a Financial Evaluation and comparison as set out in Section VI Evaluation Criteria.
- 3.29.2 Where other currencies are used, KPLC will convert those currencies to the same currency using the selling exchange rate ruling on the date of tender closing provided by the Central Bank of Kenya.
- 3.29.3 Arithmetical errors shall not be corrected. The tender sum as submitted and read out during the tender opening shall be absolute and final and shall not be the subject of correction, adjustment or amendment in any way by any person or entity.

3.30 Preferences

- 3.30.1 Subject to availability and realization of the applicable international or local standards, only such manufactured articles, materials or supplies wholly mined and produced in Kenya shall be subject to preferential procurement.
- 3.30.2 Despite the above provisions, preference shall be given to —
 - (a) manufactured articles, materials and supplies partially mined or produced in Kenya or where applicable have been assembled in Kenya; or
 - (b) firms where Kenyans are shareholders.
- 3.30.3 The threshold for the provision under 3.30.2 (b) shall be above fifty-one percent of Kenyan shareholders.
- 3.30.4 Where a person is entitled to more than one preference scheme, the scheme with the highest advantage to the person shall be applied.
- 3.30.5 In the evaluation of tenders, exclusive preference shall firstly be given to citizen contractors where the amount of the tender as evaluated is below Ksh. 500 Million in respect of works, goods and services.

3.30.6 For purposes of this paragraph the Tenderer shall submit with its Tender, a valid copy of certificate of Confirmation of Directorships and Shareholding issued **and signed** by either the Registrar of Companies or Registrar of Business Names. This certificate must not be more than three (3) months old from the Date of the Tender Document. Kenya Power reserves the right to subject the certificate to authentication.

3.31 Debarment of a Tenderer

A Tenderer who gives false information in the Tender about its qualification or who refuses to enter into a contract after notification of contract award shall be considered for debarment from participating in future public procurement.

3.32 Confirmation of Qualification for Award

3.32.1 KPLC may confirm to its satisfaction whether the Tenderer that is selected as having submitted the lowest evaluated responsive tender is qualified to perform the contract satisfactorily.

3.32.2 The confirmation will take into account the Tenderer's financial, technical, and production capabilities. It will be based upon an examination of the documentary evidence of the Tenderer's qualifications submitted by the Tenderer, pursuant to paragraph 3.13 as well as confirmation of such other information as KPLC deems necessary and appropriate. This may include factory and other facilities inspection and audits.

3.32.3 An affirmative confirmation will be a prerequisite for award of the contract to the Tenderer. A negative confirmation will result in rejection of the Tenderer's Tender, in which event KPLC will proceed to the next lowest evaluated responsive tender to make a similar confirmation of that Tenderer's capabilities to perform satisfactorily.

3.33 Award of Contract

3.33.1 KPLC will award the contract to the successful Tenderer whose Tender has been determined to be substantially responsive, technically compliant and has been determined to be the lowest evaluated tender, and further, where deemed necessary, that the Tenderer is confirmed to be technically and financially qualified to perform the contract satisfactorily.

3.33.2 Award will be done as indicated in the Appendix to Instructions to Tenderers.

3.34 Termination of Procurement Proceedings

3.34.1 KPLC may at any time terminate procurement proceedings before entering into a contract and shall not be liable to any person for the termination.

3.34.2 KPLC shall give prompt notice of the termination to the Tenderers, and, on request from any Tenderer, give its reasons for termination within fourteen (14) days of such request.

3.35 Notification of Award

- 3.35.1 Prior to the expiration of the period of tender validity, KPLC shall notify the successful Tenderer in writing that its Tender has been accepted.
- 3.35.2 The notification of award shall not constitute the formation of the contract until one is finally signed by both parties.
- 3.35.3 Simultaneously, and without prejudice to the contents of paragraph 3.35, on issuance of Notification of Award to the successful Tenderer, KPLC shall notify each unsuccessful Tenderer.
- 3.35.4 A notification of the tender outcome does not reduce the validity period for any tender security whether the Tenderer is successful or not, except where such tender security is officially released to the Bank and/or the Tenderer and such Bank discharged of all its obligations by KPLC prior to the expiry of its stated validity period.

3.36 Signing of Contract

- 3.36.1 At the same time as KPLC notifies the successful Tenderer that its Tender has been accepted, KPLC will send the Tenderer the Contract Agreement provided in the Tender Document together with any other necessary documents incorporating all agreements between the Parties.
- 3.36.2 Within fourteen (14) days of the date of notification of award, the successful Tenderer shall only sign the Contract Form and all the documents specified in that Form and return them to KPLC within that period of fourteen (14) days.
- 3.36.3 KPLC shall sign and date the Contract in the period between not earlier than fourteen (14) days from the date of notification of contract award. Further, KPLC shall not sign the contract until and unless the authentic performance security is received in accordance with paragraph 3.37.
- 3.36.4 Failure of the successful Tenderer to sign the Contract, the award shall be annulled and its tender security forfeited in which event KPLC shall notify the next lowest evaluated Tenderer that its Tender has been accepted.
- 3.36.5 Paragraph 3.37 together with the provisions of this paragraph 3.36 will apply with necessary modifications with respect to the Tenderer notified under sub-paragraph 3.35.4.

3.37 Performance Security

- 3.37.1 Within fourteen (14) days of the date of notification of award from KPLC, the successful Tenderer shall furnish KPLC with a Performance Security which shall be either one or a combination of the following:

- a) an original Bank Guarantee that is strictly in the form and content as prescribed in the Performance Security Form (Bank Guarantee) in the Tender Document.
 - b) For Local bidders, Standby Letters of Credit (LC). All costs, expenses and charges levied by all banks party to the LC shall be prepaid/borne by the Tenderer. The LC must contain all the mandatory conditions of payment to KPLC as prescribed in the Tender Security (Letters of Credit) provided in the Tender Document.
 - c) For Foreign bidders, Standby Letters of Credit (LC) confirmed by a bank in Kenya. All costs, expenses and charges levied by all banks party to the LC including confirmation charges shall be prepaid/borne by the Tenderer. The LC must contain all the mandatory conditions of payment to KPLC as prescribed in the Tender Security (Letters of Credit) provided in the Tender Document.
- 3.37.2 The Performance Security shall be denominated in Kenya Shillings or in another freely convertible currency in Kenya. A Performance Security in form of a Bank Guarantee or a Standby Letter of Credit issued on behalf of local bidders, should be from a commercial bank licensed by the Central Bank of Kenya. A Performance Security in form of a Standby Letter of Credit issued on behalf of foreign bidders by foreign banks should be confirmed by a commercial bank licensed by the Central Bank of Kenya.
- 3.37.3 The Performance Security shall be the sum of ten percent (10%) of the contract value. It shall be in the currency of the contract price.
- 3.37.4 KPLC shall seek authentication of the Performance Security from the issuing bank. It is the responsibility of the successful Tenderer to sensitize its issuing bank on the need to respond directly and expeditiously to queries from KPLC. The period for response shall not exceed three (3) days from the date of KPLC's query. Should there be no conclusive response by the Bank within this period, such successful Tenderer's Performance Security may be deemed as invalid.
- 3.37.5 Failure of the successful Tenderer to furnish an authentic Performance Security, the award shall be annulled and the Tender Security forfeited, in which event KPLC may notify the next lowest evaluated Tenderer that it's Tender has been accepted.
- 3.37.6 Without prejudice to sub-paragraph 3.37.5, failure of the successful Tenderer to furnish an authentic Performance Security, during the existence of a running Contract, the Performance Security of the running Contract shall be liquidated by KPLC before expiry of the same.

3.38 Corrupt or Fraudulent Practices

- 3.38.1 KPLC requires that Tenderers observe the highest standard of ethics during the procurement process and execution of contracts. When used in the present Regulations, the following terms are defined as follows: -

- a) *“Corrupt practice” means the offering, giving, receiving or soliciting of anything of value to influence the action of public official in the procurement process or in contract execution;*
- b) *“Fraudulent practice” means a misrepresentation of facts in order to influence a procurement process or the execution of a contract to the detriment of KPLC, and includes collusive practice among Tenderers (prior to or after Tender submission) designed to establish tender prices at artificial non-competitive levels and to deprive KPLC of the benefits of free and open competition.*
3. 38.2 KPLC will nullify its notification of award if it determines that the Tenderer recommended has engaged in corrupt or fraudulent practices in competing for the contract in question.
3. 38.3 Further, a Tenderer who is found to have indulged in corrupt or fraudulent practices risks being debarred from participating in public procurement in Kenya.

APPENDIX TO INSTRUCTIONS TO TENDERERS

The following information regarding the particulars of the tender shall complement and or amend the provisions of the Instructions to Tenderers *hereinafter abbreviated as ITT*. Wherever there is a conflict between the provisions of the ITT and the Appendix, the provisions of the Appendix herein shall prevail over those of the ITT.

No.	ITT Reference Clause	Particulars of Appendix
1.	3.2.1 Eligible Tenderers	<i>This Invitation to Tender is open to Manufacturers or Agents/Authorized suppliers. A manufacturer can quote directly OR authorize any number of Agents/Authorized Suppliers to quote products from their factory.</i>
2.	3.3.1 Origin of Eligible goods	<i>Tender shall specify origin of goods</i>
3.	3.9 (e) Documents Comprising the Tender – List of Previous Customers	<i>The tenderer to provide a list of previous customers and their contacts for similar goods supplied.</i>
4.	3.13.3 (a) Manufacturer’s Authorization	<i>1. Manufacturer’s Authorization required (Lot1). 2. Cisco partnership certificates for routers (Lot2).</i>
5.	3.13.3 (b) Documentary evidence of financial capability	<i>The audited financial statements required must be those that are reported within eighteen (18) calendar Months of the date of the tender document. (For companies or firms that are registered or incorporated within the last one calendar year of the Date of the Tender Document, they should submit certified copies of bank statements covering a period of at least six months prior to the date of the</i>

		<i>tender document. The copies should be certified by the Bank issuing the statements. The certification should be original).</i>
6.	3.13.3 (c) and (d) Documents of evidence of eligibility	<i>Applicable for this tender as per paragraph 3.2 of the ITT</i>
7.	3.14.3 (a) Catalogues, Brochures, Manufacturer's Drawings	<i>Catalogues/brochures are required.</i>
8.	3.15.1 Sample(s)	<i>Not required</i>
9.	3.16.2 Warranty – Period of	<i>1 year</i>
10.	3.17.1 Tender Security	<i>The Tender Security shall be: (a) Lot 1 KShs. 180,000.00 (b) Lot 2 Kshs. 110,000.00. However, the Original Tender Securities, in envelopes clearly labelled with the tender number & name, shall be deposited in the Tender Security Box on Ground Floor (near Reception) of KPI (KPLC Training School) on or before the opening date and time.</i>
11	3.10 Tender Form.	<i>The tenderer shall fill and submit a tender form for each lot.</i>
12.	3.34.2 Award of Contract	<i>The tender is divided into two lots .Bidders are eligible to quote for both lots. However, award shall be made to the lowest compliant bidder in each lot.</i>

SECTION IV - SCHEDULE OF REQUIREMENTS

Part A - Brief Schedule Of Details On Goods Required

LOT 1: SUPPLY AND DELIVERY OF FIBER OPTIC CABLES, TOOLS AND ACCESSORIES

1.0 FIBER OPTIC CABLE AND INSTALLATION ACCESSORIES

Item No.	Brief Description	Unit of measure	Quantity
1.	ADSS Fiber Optic cable 48 core [single mode 9/125µm]	KM	18
2.	Optical Fiber Approach Cable [48 core]	KM	1
3.	Universal Clamps (Adjustable with minimum diameter 210 – 240mm)	Set	213
4.	Suspension Clamps	Set	213
5.	Tension Clamps	Set	80
6.	Protection rods	Set	100
7.	Guy grips	Piece	70
8.	Aeolian Vibration Dampers	Piece	70
9.	Transformer by -pass Arms (Extension Arms)	Piece	10
10.	4-Way Splice boxes (plastic dome)	Piece	15
11.	FOC Storage kits	Piece	15
12.	48-Port Rack Mount Optical Distribution Frame (ODF), SC complete with pigtails, adaptors	Piece	6

1.1. FIBER OPTIC CABLE SPLICING ACCESSORIES

Item No.	Brief Description	Unit of Measure	Quantity
1.	Splice Protection Heat Shrinkable sleeve	Packet	100
2.	Self-fusing cable jointing tape	Piece	5
3.	Fiber optic Cleaning Swabs [1.25mm to 2.5mm]	Packet	100
4.	½ inch Masking tape	Piece	4
5.	UV protected Cable ties 104mm [small]	Packet	100
6.	HI-GRIP Stainless Steel Slotted Hose Clip Worm Drive, 9mm Band Width, 11mm - 16mm Inside Diameter	Pieces	100

1.2. FIBER OPTIC CABLE MAINTENANCE EQUIPMENT

I Item no.	Brief Description	Unit of Measure	Quantity
1.	Portable Tent	Piece	1
2.	Portable chairs	Piece	3
3.	Portable table	Piece	1
4.	Portable Diesel Generator	Set	1
5.	6-way surge protected Power extension cable (5meters)	Piece	1
6.	LED flood light fitting – 70watts	Piece	1
7.	Cordless Handheld Drill and Kit	Piece	1

LOT 2: SUPPLY AND DELIVERY OF INTEGRATED SERVICE ROUTERS, WAN INTERFACE CARDS, SFP MODULES AND PATCH CORDS.

Item No	ITEM	Description	Unit of Measure	Quantity
1	Cisco ISR 4431 Router	Cisco 4431 integrated services router 3 Network interface Modules (NIM) slots 4 WAN or LAN ports- 10/100/1000 ports 4 SFP based ports 4 RJ-45 based ports 8 GB Flash Memory 2 GB DRAM -Data plane 4GB DRAM – Control plane 500Mbps aggregate throughput 1 USB console port 1 Serial Console port- RJ45 Dual Power supply: Primary and Secondary Combination of AC & DC power supply AC input voltage 100 to 240VAC DC input voltage 48V- 60V Router Warranty: 1 year	PCS	3
2	EHWIC-1GE-SFP-CU CARD	Cisco Enhanced High-Speed WAN Interface Cards Cisco Gigabit Ethernet Dual-Identity Small Form-Factor Pluggable and Copper Enhanced High-Speed WAN Interface Card	PCS	2
3	SFP modules	GLC-EX-SM Cisco Compatible 1000BASE-EX SFP, 1310nm DFB, 40km over single mode fiber	PCS	2
4		1000BASE-LX/LH (GLC-LH-SM) 1310nm, 10Km		2
5	SFP modules Must be compatible for use in ABB FOX 615/515 Multiplexers	1000BASE-EX SFP, 1310nm, ,30km over SMF, Rx sensitivity -25dBm, Dual LC connector	PCS	6
6	Single Mode Media Convertors	Single Mode Media Convertors SC, 10/100Base TX UTP, 10/100 Base FX, SC type, support upto 30Km	PCS	4
7		Single Mode Media Convertors 10/100Base TX UTP,10/100 Base FX, SC type, support upto 60Km		2

8	Single mode fiber patch cord	Single mode Fiber patch cord LC-FC 20M	PCS	4
9		Single Mode Fiber patch cord SC-SC 10M		3
10		Single Mode Fiber patch cord SC-SC 20M		4
11		Single mode fiber patch cord SC-LC 20m		2
12		Single mode fiber patch cord SC-LC 5m		4
13		Single Mode Fiber patch cord SC-SC 2m		5
14		Single Mode Fiber patch cord SC-FC 10M		1
15	CAT 6 UTP patch cord	CAT 6 UTP patch cord 10m	PCS	1
16		CAT 6 UTP patch cord 5m		2
17		CAT 6 UTP patch cord 2m		2
18	Flexible conduits	25mm Flexible conduits, standard length of 30m	ROLL	2
19	Cable ties	Cable ties 200mmx 4.8mm	PKTS	8
20	Maintenance laptop	<ul style="list-style-type: none"> • Operating System: Windows 7 Professional/ Ultimate • Processor: Intel-Core i5-3360M • Memory: 4096 MB , DDR3 1600MHz; 761 MHz 10-10-10-27 timing <ul style="list-style-type: none"> • Display: 15.6 inch, 16:9, 1366 x 768 Pixel • Mainboard: Intel QM77(Panther Point) • Storage:7200 rpm SATA up to 500GB • Graphics Adapter: Intel HD Graphics 4000, Core: 350-1200 MHz, Memory : 800 MHz, 8.15.10.2639 • Battery: Minimum 97 Wh Lithium-Ion • Soundcard: Intel Panther Point PCH –High Definition Audio Controller • Ports: 1 Express Card 54mm, 2 USB 2.0, 2 USB 3.0 / 3.1 Gen1, 0 	PCS	1

		<p>Firewire, 0 Thunderbolt, 1 VGA, 1 HDMI, 0 DisplayPort, 0 S-Video, 1 Kensington Lock, 1 eSata, 1 Docking Station Port, Audio Connections: 3.5mm combo, Card Reader: 5in1 (MMC/MS/MS-PRO/SD/SDHC), 1 Fingerprint Reader</p> <ul style="list-style-type: none"> • Networking: Intel 82579LM Gigabit Network Connection (10/100/1000Mbit), Intel Centrino Advanced-N 6205 (a/b/g/n), Bluetooth 1 • Optical Drive: PLDS DVD-ROM DS-8D3H • Size: (1.38 x 15.26 x 10.7 in) • Camera: Webcam, HD • Maximum Weight: 2.87 Kg • Carrying bag: Should be supplied with a leather carrying case 		
--	--	---	--	--

***NOTES:-**

1. Tenderers must indicate the type, model (where applicable), dimensions and weight of the goods in their bid documents.
2. Tenderers shall, where applicable, indicate ready stocks and quantity if available

SECTION V - PRICE SCHEDULE FOR GOODS

(TENDERER MUST INDICATE THE CURRENCY OF THE OFFER PRICE)

LOT 1: SUPPLY AND DELIVERY OF FIBER OPTIC CABLES, TOOLS AND ACCESSORIES

(a) FIBER OPTIC CABLES AND ACCESSORIES

1	2	3	4	5	6	
Item No.	Brief Description	Quantity	Country of Origin	Unit DPP Inc.	Price VAT	Total Price DPP VAT Inc.
1.	ADSS Fiber Optic cable 48 core [single mode 9/125µm]	18				
2.	Optical Fiber Approach Cable [48 core]	1				
3.	Universal Clamps (Adjustable with minimum diameter 210 – 240mm)	213				
4.	Suspension Clamps	213				
5.	Tension Clamps	80				
6.	Protection rods	100				
7.	Guy grips	70				
8.	Aeolian Vibration Dampers	70				
9.	Transformer by -pass Arms (Extension Arms)	10				
10.	4-Way Splice boxes (plastic dome)	15				
11.	FOC Storage kits	15				
12.	48-Port Rack Mount Optical Distribution Frame (ODF), SC complete with pigtails, adaptors	6				

(b) FIBER OPTIC CABLE SPLICING ACCESSORIES

Item No.	Brief Description	Quantity	Country of Origin	Unit DPP Inc.	Price VAT	Total DPP Inc.	Price VAT
1.	Splice Protection Heat Shrinkable sleeve	100					
2.	Self-fusing cable jointing tape	5					
3.	Fiber optic Cleaning Swabs [1.25mm to 2.5mm]	100					
4.	½ inch Masking tape	4					
5.	UV protected Cable ties 104mm [small]	100					
6.	HI-GRIP Stainless Steel Slotted Hose Clip Worm Drive, 9mm Band Width, 11mm - 16mm Inside Diameter	100					

(c) FIBER OPTIC CABLE MAINTENANCE EQUIPMENT

Item No.	Brief Description	Quantity	Country of Origin	Unit Price DPP VAT Inc.	Total Price DPP VAT Inc.
1.	Portable Tent	1			
2.	Portable chairs	3			
3.	Portable table	1			
4.	Portable Diesel Generator	1			
5.	6-way surge protected Power extension cable (5meters)	1			

6.	LED flood light fitting – 70watts	1			
7.	Cordless Handheld Drill and Kit	1			

LOT 2: INTEGRATED SERVICES ROUTER, WAN INTERFACE CARDS, SFP MODULES AND LAPTOP

Item No	Item	Description	Quantity	Country of Origin	Unit Price DPP VAT Inc.	Total Price DPP VAT Inc.
1	Cisco ISR 4431 Router	Cisco 4431 integrated services router 3 Network interface Modules (NIM) slots 4 WAN or LAN ports- 10/100/1000 ports 4 SFP based ports 4 RJ-45 based ports 8 GB Flash Memory 2 GB DRAM -Data plane 4GB DRAM – Control plane 500Mbps aggregate throughput 1 USB console port 1 Serial Console port- RJ45 Dual Power supply: Primary and Secondary Combination of AC & DC power supply AC input voltage 100 to 240VAC DC input voltage 48V- 60V Router Warranty: 1 year	3			
2	EHWIC-1GE-SFP-CU CARD	Cisco Enhanced High-Speed WAN Interface Cards Cisco Gigabit Ethernet Dual-Identity Small Form-Factor Pluggable and Copper Enhanced High-Speed WAN Interface Card	2			
3	SFP modules	GLC-EX-SM Cisco Compatible 1000BASE-EX SFP, 1310nm DFB, 40km over single mode fiber	2			
4		1000BASE-LX/LH (GLC-LH-SM) 1310nm, 10Km	2			

5	SFP modules <i>Must be compatible for use in ABB FOX 615/515 Multiplexers</i>	1000BASE-EX SFP, 1310nm, 30km over SMF, Rx sensitivity -25dBm, Dual LC connector	6			
6	Single Mode Media Convertors	Single Mode Media Convertors SC, 10/100Base TX UTP, 10/100 Base FX, SC type, support upto 30Km	4			
7		Single Mode Media Convertors 10/100Base TX UTP, 10/100 Base FX, SC type, support upto 60Km	2			
8	Single mode fiber patch cord	Single mode fiber patch cord LC-FC 20M	4			
9		Single Mode Fiber patch cord SC-SC 10M	3			
10		Single Mode Fiber patch cord SC-SC 20M	4			
11		Single mode fiber patch cord SC-LC 20m	2			
12		Single mode fiber patch cord SC-LC 5m	4			
13		Single Mode Fiber patch cord SC-SC 2m	5			
14		Single Mode Fiber patch cord SC-FC 10M	1			
15	CAT 6 UTP patch cord	CAT 6 UTP patch cord 10m	1			
16		CAT 6 UTP patch cord 5m	2			
17		CAT 6 UTP patch cord 2m	2			
18	Flexible conduits	25mm Flexible conduits, standard length of 30m	2			
19	Cable ties	Cable ties 200mmx 4.8mm	8			
20	Maintenance laptop	<ul style="list-style-type: none"> • Operating System: Windows 7 Professional/ Ultimate • Processor: Intel-Core i5-3360M • Memory: 4096 MB, DDR3 1600MHz; 761 MHz 10-10-10-27 timing 	1			

		<ul style="list-style-type: none"> • Display: 15.6 inch, 16:9, 1366 x 768 Pixel • Mainboard Intel QM77(Panther Point) • Storage:7200 rpm SATA up to 500GB • Graphics Adapter: Intel HD Graphics 4000, Core: 350-1200 MHz, Memory : 800 MHz, 8.15.10.2639 • Battery: Minimum 97 Wh Lithium-Ion • Soundcard: Intel Panther Point PCH –High Definition Audio Controller • Ports: 1 Express Card 54mm, 2 USB 2.0, 2 USB 3.0 / 3.1 Gen1, 0 Firewire, 0 Thunderbolt, 1 VGA, 1 HDMI, 0 DisplayPort, 0 S-Video, 1 Kensington Lock, 1 eSata, 1 Docking Station Port, Audio Connections: 3.5mm combo, Card Reader: 5in1 (MMC/MS/MS-PRO/SD/SDHC), 1 Fingerprint Reader • Networking:Intel 82579LM Gigabit Network Connection (10/100/1000Mbit), Intel Centrino Advanced-N 6205 (a/b/g/n), Bluetooth 1 • Optical Drive: PLDS DVD-ROM DS-8D3H • Size: (1.38 x 15.26 x 10.7 in) • Camera: Webcam, HD • Maximum Weight: 2.87 Kg • Carrying bag: Should be supplied with a leather carrying case 				
--	--	--	--	--	--	--

Name of Tenderer

Name and Designation of authorized person signing the Tender

Signature of authorized person signing the Tender

Stamp of Tenderer and date

*NOTES:-

1. The offered unit price MUST be rounded to two decimal places. Where the Tenderer fails to round the offered unit price as required, then, the offered unit price shall be rounded downwards to two decimal places and used for the purposes of this tender.

SECTION VI - EVALUATION CRITERIA

Evaluation of duly submitted tenders will be conducted along the following stages: -

6.1 Part 1 - Preliminary Evaluation Criteria under Paragraph 3.28 of the ITT. These are mandatory requirements. This shall include confirmation of the following: -

6.1.1 *Submission of Tender Security - Checking its validity, whether it is Original; whether it is issued by a local bank; whether it is strictly in the format required in accordance with the sample Tender Security Form(s).*

6.1.2 *Submission of Declaration Form(s) duly completed and signed.*

6.1.3 *Submission and considering Tender Form duly completed and signed.*

6.1.4 *Submission and considering the following:-*

6.1.4.1 *For Local Tenderers*

- a) *Company or Firm's Registration Certificate*
- b) *PIN Certificate.*
- c) *Valid Tax Compliance Certificate.*
- d) *Names with full contact as well as physical addresses of previous customers of similar goods and reference letters from at least four (4) previous customers.*

6.1.4.2 *For Foreign Tenderers*

- a) *Company or Firm's Registration Certificate*
- b) *PIN Certificate or its equivalent in the country of bidder or a statement from the tax authorities in the Tenderer's country of origin indicating that such certificate or its equivalent is not issued.*
- c) *Valid Tax Compliance Certificate or its equivalent in the country of bidder or a statement from the tax authorities in the Tenderer's country of origin indicating that such certificate or its equivalent is not issued.*
- d) *Names with full contact as well as physical addresses of previous customers of similar goods and reference letters from at least three (3) previous customers.*

6.1.5 *That the Tender is valid for the period required.*

6.1.6 *Submission and considering the Confidential Business Questionnaire:-*

- a) *Is fully filled.*
- b) *That details correspond to the related information in the bid.*
- c) *That the Tenderer is not ineligible as per paragraph 3.2 of the ITT.*

6.1.7 *Submission and considering the Certificate of Confirmation of Directors (CR12)*

for registered companies and if not a registered company a business name for those trading as a sole proprietor or a partnership registered under the Kenyan law or equivalent certification for foreign tenderers.

6.1.8 Submission of Copies of relevant Type Test Certificates and their Reports or Test Certificate and their Reports from the designated bodies.

6.1.9 Submission of a copy of accreditation certificate for the testing body to ISO/IEC 17025.

6.1.10 Submission of a copy of:-

a) The Manufacturer's valid quality management system certification i.e. ISO 9001 for goods from outside Kenya.

b) valid KEBS Mark of Quality Certificate or KEBS Standardization Mark Certificate for goods manufactured in Kenya.

6.1.11 If required in the Tender Document, submission of the following-

a) Samples

b) Catalogues and/or Manufacturer's Drawings

c) Schedule of Guaranteed Technical Particulars as per tender specifications.

6.1.12 Confirming that manufacturers have authorized the bidders as necessary

6.1.13 Record of unsatisfactory or default in performance obligations in any contract shall be considered. This shall include any Tenderer with unresolved case(s) in its performance obligations for more than two (2) months in any contract.

6.1.14 Notwithstanding the above, considering any outstanding orders/Supplier Performance Review Scheme (SPRS) where applicable and the production capacity indicated by the Tenderer.

6.1.15 Submission and checking that the bill of Quantities is fully filled, priced, signed and stamped where applicable.

Tenderers will proceed to the Technical Stage only if they qualify in compliance with Part 1 above, Preliminary Evaluation under Paragraph 3.26.

6.2 Part II - Technical Evaluation Criteria Under Paragraph 3.28 of the ITT.

6.2.1 Evaluation of the following technical information against Tender Requirements and Specifications:-

6.2.1.1 For goods manufactured outside Kenya, applicable relevant valid ISO 9001 certification

6.2.1.2 For goods manufactured in Kenya - valid KEBS Mark of Quality Certificate or KEBS Standardization Mark Certificate

6.2.1.3 Type Test Certificates and their Reports or Test Certificates and their Reports from the designated bodies for full compliance with Tender Specifications

6.2.1.4 The accreditation certificate for the testing laboratory to ISO/IEC 17025.

6.2.1.5 Manufacturer's Authorization

6.2.1.6 As contained in the following documents –

- a) Manufacturer's Warranty*
- b) Catalogues and or Manufacturer's drawings*
- c) Schedule of Guaranteed Technical Particulars as per Technical Specifications.*

6.2.1.7 Cisco partnership certificate for the routers (lot2)

Tenders will proceed to the Detailed Technical Stage only if they qualify in compliance with Part II clause 6.2.1 above, Preliminary Evaluation under Paragraph 3.26

6.2.2 Detailed Technical Evaluation

- a) The Schedule of Guaranteed Technical Particulars (GTP) shall be evaluated against Tender Specifications to confirm compliance of the goods and services to the specifications and evaluation of any deviations and exceptions declared by the Tenderer.*

Detailed Technical Specification as Per Section XIX - The Technical Specifications

- b) Evaluation of compliance of submitted samples (where required) to technical specifications.*
- c) Identifying and determining any deviation(s) from the requirements; errors and oversights.*

Tenderers will proceed to Financial Evaluation stage only if they qualify in compliance with Parts I and II i.e. Preliminary and Technical stages.

**6.3 Part III – Financial Evaluation Criteria under Paragraph 3.29 of the ITT.
These are mandatory requirements.**

6.3.1 This will include the following: -

- a) *Confirmation of the authenticity and sufficiency of the submitted Tender Security.*
- b) *Confirmation of and considering Price Schedule duly completed and signed.*
- c) *Checking that the Tenderer has quoted prices based on Delivery Duty Paid (DDP) terms,*
- d) *Checking submission of audited financial statements required which must be those that are reported within eighteen (18) calendar months of the date of the tender document.*
- e) *Conducting a financial comparison, including conversion of tender currencies into one common currency,*
- f) *Taking into account the cost of any deviation(s) from the tender requirements,*
- g) *Considering information submitted in the Confidential Business Questionnaire against other information in the bid including:-*
 - i) *Declared maximum value of business*
 - ii) *Shareholding and citizenship for preferences where applicable.*
- h) *Apply preference, where applicable as per Clause 3.30 of the tender document*

6.3.2 Confirming the following: -

6.3.2.1 that the Supplier's offered Delivery Schedule meets KPLC's requirements.

6.3.2.2 that the Supplier's offered Terms of Payment meets KPLC's requirements.

6.4 The Successful Tenderer shall be the one with the lowest evaluated price.

***NOTES: -**

1. For purposes of evaluation, the exchange rate to be used for currency conversion shall be the selling exchange rate prevailing on the date of tender closing provided by the Central Bank of Kenya. (Visit the Central Bank of Kenya website).
2. Total tender value means the Tenderer's total tender price inclusive of Value Added Tax (V.A.T) for the goods it offers to supply.
3. For companies or firms that are registered or incorporated within the last one calendar year of the Date of the Tender Document, they should submit certified copies of bank statements covering a period of at least six months prior to the date of the tender

document. The copies should be certified by the Bank issuing the statements. The certification should be original.

TABLE OF CLAUSES ON GENERAL CONDITIONS OF CONTRACT

Clause No.	Headings	Page No.
7.1	Definitions.....	38
7.2	Application....	39
7.3	Country of Origin.....	39
7.4	Standards.....	39
7.5	Supplier Performance Rating Scheme.....	39
7.6	Use of Contract Documents and Information.....	39
7.7	Patent Rights.....	40
7.8	Performance Security.....	40
7.9	Approval before Manufacture.....	41
7.10	Inspections and Tests.....	41
7.11	Pre – Shipment Verification of Conformity.....	43
7.12	Consignment	43
7.13	Packaging and Labelling	43
7.14	Delivery and Documents for Goods on FOB or CFR	44
7.15	Delivery and Documents for Goods Delivered DDP.....	44
7.16	Transportation.....	44
7.17	Insurance	44
7.18	Payment.....	45
7.19	Interest.....	46
7.20	Prices.....	46
7.21	Variation of Contract.....	46
7.22	Assignment.....	47
7.23	Sub-Contracts.....	47
7.24	Termination of Contract.....	47
7.25	Liquidated Damages.....	48
7.26	Warranty.....	48
7.27	Resolution of Disputes	49
7.28	Language and Law.....	49
7.29	Waiver.....	49
7.30	Force Majeure.....	49

SECTION VII – GENERAL CONDITIONS OF CONTRACT

The General Conditions of Contract *hereinafter referred abbreviated as the GCC* shall form part of the Conditions of Contract in accordance with the law and KPLC’s guidelines, practices, procedures and working circumstances. The provisions in the GCC will apply unless an alternative solution or amendment is made under other parts of the Contract including the Special Conditions of Contract.

7.1 Definitions

In this contract, the following terms shall be interpreted as follows: -

- a) *“Day” means calendar day and “month” means calendar month.*
- b) *“The Contract” means the agreements entered into between KPLC and the Supplier, as recorded in the Contract Form signed by the parties, including all attachments and appendices thereto and all documents incorporated by reference therein.*
- c) *“The Contract Price” means the price payable to the Supplier under the contract for the full and proper performance of its contractual obligations.*
- d) *“The Goods” includes all of the equipment, machinery, and or other materials, which the Supplier is required to supply to KPLC under the contract.*
- e) *“The Procuring Entity” means The Kenya Power and Lighting Company Limited or its successor(s) and assign(s) where the context so admits (hereinafter abbreviated as KPLC).*
- f) *“The Supplier” means the individual or firm supplying the goods under this contract or his/ her/ its permitted heir(s), personal representative(s), successor(s) or permitted assign(s) where the context so admits. For the avoidance of doubt this shall mean the successful Tenderer(s) pursuant to the tender.*
- g) *Wherever used in the contract, “delivery” shall be complete or be deemed to be complete, unless the circumstances indicate otherwise, when the goods have been inspected and tested in accordance with the Contract and where KPLC does not signify its approval to the Supplier, but retains the goods without giving notice of rejection, on the expiration of thirty (30) days from date of documented receipt by the duly authorized representative of KPLC, of the goods, at KPLC stores or other indicated site.*
- h) *Supplier Rating Performance Scheme (SPRS) means the continuous evaluation of the Supplier’s performance of the contract based on the*

parameters of timely delivery, quality of goods, frequency of communication, timely response, innovation, dispute resolution.

7.2 Application

These General Conditions shall apply to the extent that provisions of other parts of the contract do not supersede them.

7.3 Country of Origin

7.3.1 For purposes of this clause, “Origin” means the place where the goods were mined, grown, or produced.

7.3.2 The origin of Goods and Services is distinct from the nationality of the Supplier.

7.4 Standards

The Goods supplied under this contract shall conform to the standards mentioned in the Technical Specifications.

7.5 Supplier Performance Rating Scheme

7.5.1 KPLC shall use a Supplier Performance Rating Scheme (SPRS) to measure the annual performance of the Supplier’s obligations and its conduct of the contract.

7.5.2 The Scheme will be updated periodically commencing with the date of execution of the contract by both parties. KPLC shall provide the Supplier with a copy of the SPRS report.

7.5.3 KPLC shall consider the Supplier’s overall performance at the end of the performance period.

7.5.4 At the request of either party, the parties shall discuss and conclude deliberations on the annual SPRS report. At any such meetings and/or for the purposes of the deliberations, KPLC Supply Chain – Procurement Department shall appoint the Chairperson as well as the Secretariat.

7.5.5 The SPRS measures shall be according to Supplier Performance Rating Form in Section XXVIII

7.5.6 A KP1, KP2 & KP3 assessment of the Supplier on the SPRS will be a consideration for continued engagement between the parties in the subsequent year. A KP4 assessment of the Supplier shall be a termination event.

7.6 Use of Contract Documents and Information

7.6.1 The Supplier shall not, without KPLC’s prior written consent, disclose the contract, or any provision thereof or any specification, plan, drawing, pattern, sample, or information furnished by or on behalf of KPLC in connection therewith, to any person other than a person employed by the Supplier in the performance of the contract.

- 7.6.2 The Supplier shall not, without KPLC's prior written consent, make use of any document or information enumerated in clause 7.6.1 above.
- 7.6.3 Any document, other than the contract itself, enumerated in clause 7.6.1 shall remain the property of KPLC and shall be returned (including all copies) to KPLC on completion of the Supplier's performance under the contract if so required by KPLC.

7.7 Patent Rights

The Supplier shall indemnify KPLC against all third party claims of infringement of patent, trademark, or industrial design rights arising from use of the goods of any part thereof in KPLC's country.

7.8 Performance Security

- 7.8.1 Within fourteen (14) days of the date of the notification of contract award, the Supplier shall furnish to KPLC the Performance Security which shall be either one or a combination of the following:-
- a) an original Bank Guarantee that is strictly in the form and content as prescribed in the Performance Security Form (Bank Guarantee) in the Tender Document.
 - b) Confirmed Standby Letters of Credit (LC). All costs, expenses and charges levied by all banks party to the LC including confirmation charges shall be prepaid by the successful Tenderer. Certain mandatory conditions of the LC shall be as prescribed in the Performance Security Form (LC) in the Tender Document.
- 7.8.2 The Performance Security shall be issued by a commercial bank licensed by the Central Bank of Kenya. The bank must be located in Kenya.
- 7.8.3 The Performance Security shall be the sum of ten percent (10%) of the contract price. It shall be in the currency of the contract price.
- 7.8.4 Failure of the Supplier to furnish the Performance Security, the award shall be annulled and the Tender Security forfeited, in which event KPLC may notify the next lowest evaluated Tenderer that its Tender has been accepted.
- 7.8.5 The proceeds of the Performance Security shall be payable to KPLC as compensation for any loss resulting from the Supplier's failure to comply with its obligations in accordance with the contract without KPLC being required to demonstrate the loss it has suffered.
- 7.8.6 The Performance Security shall be valid for a minimum of sixty (60) days after satisfactory delivery for both Foreign and Local Suppliers.
- 7.8.7 KPLC shall seek authentication of the Performance Security from the issuing bank. It is the responsibility of the Supplier to sensitize its issuing bank on the need to respond directly and expeditiously to queries from KPLC. The period for response shall not exceed five (5) days from the date of KPLC's query. Should there be no conclusive response by the Bank within this period, such Supplier's

Performance Security may be deemed as invalid and the Contract nullified, unless information to the contrary is received by KPLC two (2) days before the expiry of the Supplier's Tender Security.

- 7.8.8 Subject to the provisions of this contract, the Performance Security will be discharged by KPLC and returned to the Supplier not earlier than sixty (60) days following the date of completion of the Supplier's obligations under the contract, including any warranty obligations, under the contract.

7.9 Approval Before Manufacture

- 7.9.1 All technical details and design drawings for the items to be supplied shall be submitted by the Supplier to KPLC for approval before manufacture.
- 7.9.2 Should the Supplier fail to observe this condition of approval before manufacture, KPLC may decline to accept the goods, or the Supplier shall either replace them or make alterations necessary, but in any case, KPLC shall incur no liability howsoever.

7.10 Inspection and Tests

- 7.10.1 KPLC or its representative shall have the right to inspect and/or to test the goods to confirm their conformity to the contract specifications. KPLC shall notify the Supplier in writing in a timely manner, of the identity of any representative(s) retained for these purposes.
- 7.10.2 Prior to the manufacture or production of the goods on order, KPLC reserves the right to inspect the manufacturing or production facility and the quality management system. The manufacturer or producer shall meet the cost of routine inspection while KPLC shall meet the cost of air travel to the nearest airport and accommodation of two of its nominated officers inspecting and witnessing tests.
- 7.10.3 It is the responsibility of the Supplier to confirm if this right is to be exercised. Such visit and or inspection shall in no way prejudice KPLC's rights and privileges.
- 7.10.4 Upon completion of manufacturing or production process, KPLC reserves the right to send two of its nominated officers to inspect the goods on order at the place of manufacture where inspection and acceptance tests as per tender specifications shall be carried out in their presence. Tests shall be done in accordance with the test standard(s) given in the Technical Specification of the goods on order.
- 7.10.5 The manufacturer or producer shall meet the cost of tests as per tender specifications while KPLC shall meet the cost of air travel to the nearest airport and accommodation of its two nominated officers inspecting and witnessing the tests.
- 7.10.6 The inspections and tests may be conducted on the premises of the Supplier or its subcontractor(s), at point of production, manufacture, delivery and or at the goods' final destination. If conducted on the premises of the Supplier or its

- Subcontractor, all reasonable facilities and assistance, including access to drawings and production data, shall be furnished to the inspectors at no charge to KPLC. In all cases, the equipment used for tests must be validly calibrated by the national standards body and a copy of the calibration certificate(s) must be submitted with the test report(s).
- 7.10.7 Complete test report(s) for all the goods as per Tender Specifications shall be submitted to KPLC for approval before packaging and shipment. No material or goods shall be shipped or delivered without written approval from KPLC.
- 7.10.8 Should any inspected or tested goods fail to conform to the specifications, KPLC shall reject the goods, and the Supplier shall either replace the rejected goods or make alterations necessary to meet specification requirements free of cost to KPLC. The period for replacement or alterations together with delivery to KPLC shall be fourteen (14) days or as may otherwise be specified in the notice of rejection.
- 7.10.9 The Supplier shall collect the rejected goods within fourteen (14) days from the date of notification of rejection. If the rejected goods are not collected within this period, they shall attract storage and handling charges at prevailing market rates or as determined by KPLC without making any reference to the supplier pending the disposal of the goods by KPLC as guided by the Disposal of Uncollected Goods Act, Chapter 38 of the Laws of Kenya.
- 7.10.10 Notwithstanding any previous inspection(s) and test(s) KPLC shall inspect and may test the goods upon arrival at the indicated site. Where KPLC inspects and rejects the goods after the goods arrival, KPLC shall claim from the Supplier the full cost of the goods including delivery charges to KPLC Stores or other indicated site and other incidental costs incurred in relation thereof.
- 7.10.11 KPLC's right to inspect, test and where necessary, reject the goods after their arrival shall in no way be limited or waived by reason of the goods having previously been inspected, tested and passed by KPLC or its representative(s) prior to the goods delivery.
- 7.10.12 For the avoidance of doubt, any acknowledgement by KPLC on the Supplier's or sub-contractor's document shall not be conclusive proof or evidence of satisfactory delivery without duly authorized approval by KPLC.
- 7.10.13 Nothing in clause 7.10 shall in any way release the Supplier from any warranty or other obligations under this Contract.
- 7.11 Pre-Shipment Verification of Conformity (PVoC)**
- 7.11.1 All Suppliers of imported goods and or products must obtain a Certificate of Conformity issued by an authorized KEBS appointed partner prior to shipment.
- 7.11.2 The Certificate is a mandatory customs clearance document in Kenya. KEBS has appointed a number of Inspection Bodies to perform the PVoC programme on

their behalf depending on the country of supply origin. The cost of pre-shipment verification shall be borne by the Supplier.

Full information on authorized inspection bodies should be obtained from KEBS.

7.12 Consignment

- 7.12.1 The terms shall be strictly on Delivered and Duty Paid (DDP) basis.
- 7.12.2 The Consignee shall be the supplier or supplier's agent whose responsibilities shall include payment of all Customs taxes, duties and levies, clearance of the goods, and delivery to KPLC stores. For avoidance of doubt, this includes Value Added Tax (VAT), Railway Development Levy (RDL) and Import Duties.

7.13 Packaging and Labelling

- 7.13.1 The Supplier shall provide such packaging of the goods as is required to prevent their damage or deterioration during transit to their final destination, as indicated in the contract.
- 7.13.2 The method of packaging, labeling and marking shall comply strictly with such special requirements as shall be specified in the special condition of contract.
- 7.13.3 The labelling, marking and documentation within and outside the packages shall comply strictly with such special requirements as shall be expressly provided for in the contract.
- 7.13.4 The goods shall be packed in good condition suitable for sea/air/road/rail dispatch. Hazard in transit to the final destination shall include rough handling and storage in tropical conditions.
- 7.13.5 The Supplier shall enclose a packing list in each package and all documents relating to the Order shall show the Stores Code Number detailed against the items.
- 7.13.6 The labeling on each package shall include the following;
 - (i) General description of the item(s)
 - (ii) KPLC Order No.....
 - (iii) Cautionary notes and handling instructions
 - (iv) Package number

7.14 Delivery and Documents for Goods on FOB or CFR.

This is not applicable for this tender

7.15 Delivery and Documents for Goods on Delivered Duty Paid (DDP) Terms.

- 7.15.1 Delivery of the goods shall be made by the Supplier to the place and in accordance with the terms specified by KPLC in its Schedule of Requirements.
- 7.15.2 The Supplier shall notify KPLC of the full details of the delivered goods by delivering together with the goods a full set of the following documents:-

- a) Supplier's invoice showing the goods description, quantity, unit price and total price,
 - b) Delivery note for every consignment originating from the party contracted by KPLC. The Delivery Note should be serialized, dated and contain the number of the Official Purchase Order,
 - c) Copy of the Certificate of Conformity (CoC),
 - d) Manufacturer's warranty certificate and
 - e) Packing list identifying contents of each package which list should include casing number, full description of the items and the quantities in each package.
- 7.15.3 It is the responsibility of the Supplier to ensure that the delivery documents are received by KPLC at the designated delivery point at the time of delivery.
- 7.15.4 Any late or non-submission of the delivery documents shall be treated as part of non-performance on the part of the Supplier and KPLC shall be entitled to call up the Performance Security.
- 7.15.5 The Supplier should notify KPLC in writing of its intention to deliver goods fourteen (14) days prior to delivery, and a further confirmation two (2) working days before actual delivery to the designated delivery point.

7.16 Transportation

- 7.16.1 The Supplier shall be required to meet all transport expenses until delivery.

7.17 Insurance

- 7.17.1 The Supplier shall (except in respect to losses, injuries or damage resulting from any act or neglect of KPLC) indemnify and keep indemnified KPLC against all losses and claims for injuries or damage to any person or property whatsoever which may arise out of or in consequence of the contract and against all claims, demands, proceedings, damages, costs, charges, and expenses whatsoever in respect thereof or in relation thereto.

7.18 Payment

- 7.18.1 Payments shall be made promptly by KPLC thirty (30) days from delivery and submission of invoice together with other required and related documents or as otherwise prescribed in the contract.
- 7.18.2 The credit period shall be thirty (30) days from satisfactory delivery and submission of invoice together with other required and related documents.
- 7.18.3 Upon satisfactory delivery and submission of invoice together with other required and related documents, KPLC shall pay for the goods after the credit period.
- 7.18.4 Payment shall primarily be through KPLC's cheque or Real Time Gross Settlement (RTGS) for local based suppliers or Telegraphic Transfer (TT) for foreign based suppliers.

- 7.18.5 Suppliers who are to be paid through RTGS or TT must ensure that they submit the following:
- a) invoice containing the Bank's Name and Branch,
 - b) Name/Title of Bank account,
 - c) Bank account number
 - d) SWIFT CODE.
 - e) A letter signed by the authorized signatory of the bank account of the Tenderer confirming details (a) to (d) above. This letter must contain the name of that authorized signatory and a Board Resolution that is sealed.
- 7.18.6 Where applicable, a copy of a valid Performance Security, stamped, certified as authentic by KPLC, shall form part of the documents to be presented to KPLC before any payment is made.
- 7.18.7 The terms shall be strictly on Delivered and Duty Paid (DDP).
- 7.18.8 Suppliers who request for a Letter of Credit (*hereinafter abbreviated as LC*) –
- a) *shall submit proforma invoices containing the advising Bank's Name and Branch, Name/Title of Bank account, Bank account number and the SWIFT CODE; where required, proposed confirming bank; LC validity period and any other details that may be required to facilitate this process.*
 - b) *Shall meet all the LC bank charges levied by both its bank and KPLC's bank as well as any other bank that is a party to the LC.*
 - c) *Any extension and or amendment charges and any other costs that may result from the Supplier's delays, requests, mistakes or occasioned howsoever by the Supplier shall be to the Beneficiary's account.*
 - d) *The maximum number of extensions and amendments shall be limited to two (2).*
 - e) *Notwithstanding sub-clause 7.18.6, should the Supplier require a confirmed LC, then all confirmation and any other related charges levied by both the Supplier's and KPLC's bank as well as any other bank party to such confirmation shall be to the Beneficiary's account.*
 - f) *LCs shall be -*
 - (i.) *partial for partial performance*
 - (ii.) *Opened only for the specific deliveries in accordance with the delivery schedule indicated in the Official Purchase Order or any formal note amending that Order.*
 - (iii.) *Revolving subject to the maximum annual value of total quantity indicated in the Official Purchase Order*
 - (iv.) *Without prejudice to any other provision of the contract, valid for a maximum period of one year.*
 - g) *The Supplier shall be required to submit a proforma invoice for each lot for use in the placement of order and opening of the LC. The proforma invoice shall be on total DDP basis.*

h) *A copy of the Performance Security, stamped and certified as authentic by KPLC, whose expiry date should not be less than sixty (60) days from the LC expiry date, shall form part of the documents to be presented to the Bank before any payment is effected.*

7.18.9 KPLC shall have the sole discretion to accept or decline any Supplier's payment request through Letters of Credit without giving any reason for such decline.

7.19 Interest

Interest payment by KPLC is inapplicable in the contract.

7.20 Prices

7.20.1 Subject to clause 7.19 herein-below, prices charged by the Supplier for goods delivered and services performed under the contract shall, be fixed for the period of the contract with no variations.

7.21 Variation of Contract

KPLC and the Supplier may vary the contract only in accordance with the following: -

- a) *the quantity variation for goods shall not exceed ten percent (15%) of the original contract quantity.*
- b) *The cumulative value variation shall not exceed twenty five percent (25%) of the original contract value.*
- c) *the quantity variation must be executed within the period of the contract.*

7.22 Assignment

The Supplier shall not assign in whole or in part its obligations to perform under this contract, except with KPLC's prior written consent.

7.23 Subcontracts

7.23.1 The Supplier shall notify KPLC in writing of all subcontracts awards under this contract if not already specified in the tender. Such notification, in the original tender or obligation under the Contract shall not relieve the Supplier from any liability or obligation under the Contract.

7.23.2 In the event that an award is given and the contract is sub contracted, the responsibility and onus over the contract shall rest on the Supplier who was awarded.

7.24 Termination of Contract

- 7.24.1 KPLC may, without prejudice to any other remedy for breach of contract, by written notice sent to the Supplier, terminate this contract in whole or in part due to any of the following: -
- a) *if the Supplier fails to deliver any or all of the goods within the period(s) specified in the contract, or within any extension thereof granted by KPLC.*
 - b) *if the Supplier fails to perform any other obligation(s) under the contract.*
 - c) *if the Supplier, in the judgment of KPLC has engaged in corrupt or fraudulent practices in competing for or in executing the contract.*
 - d) *by an act of force majeure.*
 - e) *if the Supplier becomes insolvent or bankrupt*
 - f) *if the Supplier has a receiving order issued against it, compounds with its creditors, or an order is made for its winding up (except for the purposes of its amalgamation or reconstruction), or a receiver is appointed over its or any part of its undertaking or assets, or if the Supplier suffers any other analogous action in consequence of debt.*
 - g) *if the Supplier abandons or repudiates the Contract.*
- 7.24.2 KPLC by written notice sent to the Supplier may terminate the Contract in whole or in part, at any time for its convenience. The notice of termination shall specify that the termination is for KPLC's convenience, the extent to which performance, by the Contractor, of the Contract, is terminated and the date on which such termination becomes effective.
- 7.24.3 For the remaining part of the Contract after termination for convenience, KPLC may pay to the Supplier an agreed amount for partially completed satisfactory deliveries.
- 7.24.4 In the event that KPLC terminates the contract in whole or in part, it may procure, upon such terms and in such manner as it deems appropriate, goods similar to those undelivered or not rendered, and the Supplier shall be liable to KPLC for any excess costs for such similar goods and or any other loss PROVIDED that the Supplier shall not be so liable where the termination is for convenience of KPLC.
- 7.24.5 The Parties may terminate the Contract by reason of an act of *force majeure* as provided for in the contract.
- 7.24.6 The Contract may automatically terminate by reason of an act of *force majeure* as provided for in the Contract.

7.25 Liquidated Damages

Notwithstanding and without prejudice to any other provisions of the contract, if the Supplier fails to deliver any or all of the goods within the period specified in the contract, KPLC shall, without prejudice to its other remedies under the contract, deduct from the contract prices, liquidated damages sum equivalent to

0.5% of the delivered or shipment price (whichever is applicable) per day of delay of the delayed items up to a maximum of ten percent (10%) of the delivered price of the delayed goods.

7.26 Warranty

- 7.26.1 The Supplier warrants that the goods supplied under the contract are new, unused, of the most recent or current specification and incorporate all recent improvements in design and materials unless provided otherwise in the contract. The Supplier further warrants that the goods supplied under this contract shall have no defect arising from manufacture, materials or workmanship or from any act or omission of the Supplier that may develop under normal use of the supplied goods under the conditions obtaining in Kenya.
- 7.26.2 This warranty will remain valid for the period indicated in the special conditions of contract after the goods, or any portion thereof as the case may be, have been delivered to the final destination indicated in the contract.
- 7.26.3 KPLC shall promptly notify the Supplier in writing of any claims arising under this warranty.
- 7.26.4 Upon receipt of such a notice, the Supplier shall, with all reasonable speed, replace the defective goods without cost to KPLC.
- 7.26.5 If the Supplier having been notified, fails to remedy the defect(s) within a reasonable period, KPLC may proceed to take such remedial action as may be necessary, at the Supplier's risk and expense and without prejudice to any other rights which KPLC may have against the Supplier under the contract.

7.27 Resolution of Disputes

- 7.27.1 KPLC and the Supplier may make every effort to resolve amicably by direct informal negotiation any disagreement or dispute arising between them under or in connection with the contract.
- 7.27.2 If, after thirty (30) days from the commencement of such informal negotiations both parties have been unable to resolve amicably a contract dispute, either party may resort to resolution before a recognized local forum for the resolution of disputes.

7.28 Language and Law

The language of the contract and the law governing the contract shall be the English language and the laws of Kenya respectively unless otherwise stated.

7.29 Waiver

Any omission or failure by KPLC to exercise any of its rights or enforce any of the penalties arising from the obligations imposed on the Supplier shall in no way,

manner or otherwise howsoever, alter, amend, prejudice, vary, waive or be deemed to alter, amend, prejudice, vary, waive or otherwise whatsoever any of KPLC's powers and rights as expressly provided in and as regards this contract.

7.30 Force Majeure

7.30.1 *Force majeure* means any circumstances beyond the control of the parties, including but not limited to: -

- a) *war and other hostilities (whether war be declared or not), invasion, act of foreign enemies, mobilization, requisition or embargo;*
- b) *ionizing radiation or contamination by radio-activity from any nuclear fuel or from any nuclear waste from the combustion of nuclear fuel, radioactive toxic explosives or other hazardous properties of any explosive nuclear assembly or nuclear components thereof;*
- c) *rebellion, revolution, insurrection, military or usurped power and civil war;*
- d) *riot, commotion or disorder except where solely restricted to employees servants or agents of the parties;*
- e) *un-navigable storm or tempest at sea.*

7.30.2 Notwithstanding the provisions of the contract, neither party shall be considered to be in default or in breach of its obligations under the contract to the extent that performance of such obligations is prevented by any circumstances of *force majeure* which arise after the Contract is entered into by the parties.

7.30.3 If either party considers that any circumstances of *force majeure* are occurring or have occurred which may affect performance of its obligations it shall promptly notify the other party and provide reasonable proof of such circumstances.

7.30.4 Upon the occurrence of any circumstances of *force majeure*, the Supplier shall endeavour to continue to perform its obligations under the contract so far as is reasonably practicable. The Supplier shall notify KPLC of the steps it proposes to take including any reasonable alternative means for performance, which is not prevented by *force majeure*. The Supplier shall not take any such steps unless directed so to do by KPLC.

7.30.5 If the Supplier incurs additional costs in complying with KPLC's directions under sub clause 7.28.4, then notwithstanding the provisions of the Contract, the amount thereof shall be agreed upon with KPLC and added to the contract price.

7.30.6 If circumstances of *force majeure* have occurred and shall continue for a period of twenty one (21) days then, notwithstanding that the Supplier may by reason thereof have been granted an extension of time for performance of the contract, either party shall be entitled to serve upon the other seven (7) days' notice to terminate the Contract. If at the expiry of the period of twenty-eight (28) days, *force majeure* shall still continue, the contract shall terminate.

SECTION VIII – SPECIAL CONDITIONS OF CONTRACT

The Special Conditions of Contract *hereinafter abbreviated as SCC* shall form part of the Conditions of Contract. They are made in accordance with the law and KPLC’s guidelines, practices, procedures and working circumstances. They shall amend, add to and vary the GCC. The clauses in this section need not therefore, be completed but must be completed by KPLC if any changes to the GCC provisions are deemed necessary. Whenever there is a conflict between the GCC and SCC, the provisions of the SCC shall prevail over those in the GCC.

CONDITIONS OF CONTRACT	CLAUSE USE	REQUIREMENT(S)
The Name and identification number of the contract		SUPPLY AND DELIVERY OF ROUTERS, FIBER OPTIC CABLES, TOOLS AND ACCESSORIES – KP1/1/3A/4/1/OT/007/18-19
Start Date		<i>After signing of the contract agreement and issuance of LPO</i>
Other documents to form part of the contract		As per tender
Delivery Location		IESR-RUARAKA
Warranty Period		<i>One Year (12 months)</i>
The Price Adjustment Clause (Shall/shall not apply)		Shall not apply
Performance Security (as a percentage of the Contract Price)		10% of contract value.
Delivery of goods (in days)		90 days
The rate of exchange for calculation of foreign currency payments		n/a
Advance payment (Shall/ Shall not be granted)		Not applicable in this tender.
Time (in days) after which payment is to be made after delivery of goods and receipt of Invoice.		30 days
Inspection and acceptance of goods		All items shall be inspected by KPLC upon delivery to check conformity with the Tender Technical Specifications

Signature and stamp of tenderer **Date:**

SECTION IX - TENDER FORM

Date:.....

Tender No.....

To:

The Kenya Power & Lighting Company Limited,
Stima Plaza,
Kolobot Road, Parklands,
P.O Box 30099 – 00100,
Nairobi, Kenya.

Ladies and Gentlemen,

1. Having read, examined and understood the Tender Document including all Addenda, the receipt of which is hereby duly acknowledged, we, the undersigned Tenderer, offer to supply, deliver, install and commission (*the latter two where applicable*) (*insert goods description*) in accordance and conformity with the said tender document for the sum of(*total tender amount inclusive of all taxes in words and figures*) or such sums as may be ascertained in accordance with the Price Schedule attached herewith and made part of this Tender.
2. We undertake, if our Tender is accepted, to deliver, install and commission the goods in accordance with the delivery schedule specified in the Schedule of Requirements.
3. If our Tender is accepted, we will obtain the performance security of a licensed commercial bank in Kenya in a sum equivalent to ten percent (10%) of the contract price for the due performance of the contract, in the form(s) prescribed by The Kenya Power & Lighting Company Limited.
- 4.* We agree to abide by this Tender for a **period of.....days (Tenderer please indicate validity of your tender)** from the date fixed for tender opening as per the Tender Document, and it shall remain binding upon us and may be accepted at any time before the expiration of that period.
5. This Tender, together with your written acceptance thereof and your notification of award, shall not constitute a contract, between us. The contract shall be formed between us when both parties duly sign the written contract.
6. We understand that you are not bound to accept any Tender you may receive.

Yours sincerely,

Name of Tenderer

Signature of duly authorized person signing the Tender

Name and Designation of duly authorized person signing the Tender

Stamp or Seal of Tenderer

***NOTES:**

1. KPLC requires a validity period of at least ninety (90) days.
2. This form must be duly completed, signed, stamped and/or sealed.

SECTION X – CONFIDENTIAL BUSINESS QUESTIONNAIRE FORM

All Tenderers are requested to give the particulars indicated in Part 1 and either Part 2 (a), 2 (b) or 2 (c) whichever applies to your type of business. Tenderers are advised that it is a serious offence to give false information on this form.

Part 1 – General

Business Name.....

Location of business premises.....

Plot No.Street/ Road

Postal Address Postal Code

Tel No.....

Facsimile.....

Mobile and CDMA No.....

E-mail:.....

Nature of your business

Registration Certificate No.....

Maximum value of business which you can handle at any time KSh.....

Name of your BankersBranch... ..

*Names of Tenderer’s contact person(s)

Designation of the Tenderer’s contact person(s)

Address, Tel, Fax and E-mail of the Tenderer’s contact person(s)

.....

.....

Part 2 (a) Sole Proprietor

Your name in full

NationalityCountry of origin

Part 2 (b) Partnership

Give details of partners as follows: -

Names	Nationality	Shares (%)
1.....		
2.....		
3.....		
4.....		
5.....		

Part 2 (c) Registered Company

Private or Public

State the nominal and issued capital of company-

*Nominal in KSh.

*Total Issued KSh.

Give details of all directors as follows

Name	Nationality	Shares (%)
1.....		
2.....		
3.....		
4.....		
5.....		

Name of duly authorized person to sign for and on behalf of the Tenderer

Designation of the duly authorized person.....

Signature of the duly authorized person.....

***NOTES TO THE TENDERERS ON THE QUESTIONNAIRE**

1. *The address and contact person of the Tenderer provided above shall at all times be used for purposes of this tender.*
2. *The details on this Form are essential and compulsory for all Tenderers. **Failure to provide all the information requested shall lead to the Tenderer's disqualification.***
3. *For foreign Tenderers please give the details of nominal and issued share capital in the currency of the country of origin of the Tenderer.*

SECTION XI A - TENDER SECURITY FORM – (BANK GUARANTEE)

(To Be Submitted On Bank’s Letterhead)

Date:

To:

The Kenya Power & Lighting Company Limited,
Stima Plaza,
Kolobot Road, Parklands,
P.O Box 30099 – 00100,
Nairobi, Kenya.

WHEREAS (*name of the Tenderer*) (*hereinafter called “the Tenderer”*) has submitted its Tender dated for the supply, installation and commissioning of..... (*Please insert KPLC tender no. and name*) (*hereinafter called “the Tender”*);

KNOW ALL PEOPLE by these presents that **WE**.....of having our registered office at.....(*hereinafter called “the Bank”*), are bound unto The Kenya Power and Lighting Company Limited (*hereinafter called “KPLC”* which expression shall where the context so admits include its successors-in-title and assigns) in the sum of for which payment well and truly to be made to the said KPLC, the Bank binds itself, its successors, and assignees by these presents.

We undertake to pay you, upon your first written demand declaring the Tenderer to be in breach of the tender requirements and without cavil or argument, the entire sum of this guarantee being (*amount of guarantee*) as aforesaid, without you needing to prove or to show grounds or reasons for your demand or the sum specified therein.

This tender guarantee will remain in force up to and including thirty (30) days after the period of tender validity, and any demand in respect thereof should reach the Bank not later than the date below.

This guarantee is valid until theday of 20.....

EITHER

SEALED with the)
COMMON SEAL)

of the said **BANK**)
thisday)
of20....)

BANK SEAL

in the presence of :-)
)
)
 _____)
)
and in the presence of:-)
)
)
 _____)

OR

SIGNED by the **DULY AUTHORISED REPRESENTATIVE(S)/ ATTORNEY(S)** of the **BANK**

Name(s) and Designation of duly authorised representative(s)/ attorney(s) of the Bank

Signature(s) of the duly authorised person(s)

NOTES TO TENDERERS AND BANKS

1. *Please note that no material additions, deletions or alterations regarding the contents of this Form shall be made to the Tender Security to be furnished by the Tenderer. If any are made, the Tender Security shall not be accepted and shall be rejected by KPLC. For the avoidance of doubt, such rejection will be treated as non-submission of the Tender Security where such Security is required in the tender.*
2. *It is the responsibility of the Tenderer to sensitize its issuing bank on the need to respond directly and expeditiously to queries from KPLC. The period for response shall not exceed three (3) days from the date of KPLC’s query. Should there be no conclusive response by the Bank within this period, such Tenderer’s Tender Security shall be deemed as invalid and the bid rejected.*
3. ***The issuing bank should address its response or communication regarding the bond to KPLC at the following e-mail address – “[guarantees@ kplc.co.ke](mailto:guarantees@kplc.co.ke)”***
4. *The Tender validity period is ninety (90) days as set out in the Invitation to Tender (at Section I of the Tender document) or as otherwise may be extended by*

KPLC. Therefore the Tender Security must at all times be valid for at least 30 days beyond the tender validity period.

SECTION XI B - TENDER SECURITY FORM (SACCO SOCIETY, DEPOSIT TAKING MICRO FINANCE INSTITUTIONS, WOMEN ENTERPRISE FUND & YOUTH ENTERPRISE FUND)

(To Be Submitted On Institutions Letterhead)

Date:

To:

The Kenya Power & Lighting Company Limited,
Stima Plaza,
Kolobot Road, Parklands,
P.O Box 30099 – 00100,
Nairobi, Kenya.

WHEREAS.....(hereinafter called “the Tenderer”) has undertaken, in pursuance of your Tender Number.....(*reference number of the Tender*) and its Tender dated(*insert Tenderer’s date of Tender taken from the Tender Form*) to supply(*description of the Goods*) (hereinafter called “the Contract);

AND WHEREAS it has been stipulated by you in the said Contract that the Tenderer shall furnish you with an Institution’s guarantee by an acceptable Institution for the sum specified therein as security for compliance of the Tenderer’s performance obligations in accordance with the Contract;

AND WHEREAS we have agreed to give the Tenderer a Guarantee;

THEREFORE WE HEREBY AFFIRM that we are Guarantors and responsible to you, on behalf of the Tenderer, up to a total of..... (*amount of the guarantee in words and figures*) and we undertake to pay you, upon your first written demand declaring the Tenderer to be in default under the Contract and without cavil or argument, any sum or sums within the limits of (*amount of guarantee*) as aforesaid, without you needing to prove or to show grounds or reasons for your demand or the sum specified therein.

This guarantee is valid until theday of... 20....

EITHER

SEALED with the)
COMMON SEAL)
of the said **INSTITUTION**)

)
thisday)
of20....)
in the presence of :-)
_____)
and in the presence of:-)
_____)

INSTITUTION SEAL

OR

SIGNED by the **DULY AUTHORISED**
REPRESENTATIVE(S)/ ATTORNEY(S) of
the **INSTITUTION**

Name(s) and Designation of duly authorised representative(s)/ attorney(s) of the
Institution.

Signature(s) of the duly authorised person(s)

NOTES TO SUPPLIERS AND INSTITUTIONS

1. *Please note that no material additions, deletions or alterations regarding the contents of this Form shall be made to the Tender Security to be furnished by the Tenderer. If any are made, the Tender Security shall not be accepted and shall be rejected by KPLC. For the avoidance of doubt, such rejection will be treated as non-submission of the Tender Security where such Security is required in the tender.*
2. *It is the responsibility of the Tenderer to sensitize its issuing institution on the need to respond directly and expeditiously to queries from KPLC. The period for response shall not exceed three (3) days from the date of KPLC's query. Should there be no conclusive response by the institution within this period, such Tenderer's Tender Security shall be deemed as invalid and the bid rejected.*
3. ***The issuing institution should address its response or communication regarding the Tender Security to KPLC at the following e-mail address – “guarantees@kplc.co.ke”***
4. *The Tender validity period is ninety (90) days as set out in the Invitation to Tender (at Section I of the Tender document) or as otherwise may be extended by KPLC. Therefore the Tender Security must at all times be valid for at least 30 days beyond the tender validity period.*

SECTION XI C - TENDER SECURITY – (LETTERS OF CREDIT)

The Mandatory Conditions to be included in the Letters are in two parts, A and B.

Part A

Form of Documentary credit - “Irrevocable Standby”

Applicable rules - “Must be UCP Latest Version” i.e. UCP 600 (2007 REVISION) ICC Publication No. 600.

Place of expiry - At the counters of the advising bank.

The SBLC should be available – “By Payment”

Drafts should be payable at - “SIGHT”

Documents required -

1. Beneficiary’s signed and dated statement demanding for payment under the letter of credit no..... (*Insert LC No.*) as.....(*Name of applicant*) (hereinafter called the “Tenderer”) indicating that the “Tenderer” has defaulted in the obligations of the Tenderer as stated by the Beneficiary.
2. The Original Letter of Credit and all amendments, if any.

Additional Conditions -

1. All charges levied by any bank that is party to this documentary credit are for the account of the applicant.
2. There should be no conditions requiring compliance with the specific regulations or a particular country’s Law and regulations.

Charges - All bank charges are for the account of the applicant.

*Confirmation instructions – (See notes below)

Part B

The proceeds of these Letters are payable to KPLC -

- a) if the Tenderer withdraws its Tender after the deadline for submitting Tenders but before the expiry of the period during which the Tenders must remain valid.
- b) if the Tenderer fails to enter into a written contract in accordance with the Tender Document
- c) if the successful Tenderer fails to furnish the performance security in accordance with the Tender Document.
- d) if the Tenderer fails to extend the validity of the tender security where KPLC has extended the tender validity period in accordance with the Tender Document.

NOTES TO TENDERERS AND BANKS.

1. *Please note that should the Tender Security (LC) omit any of the above conditions the LC shall not be accepted and shall be rejected by KPLC. For the avoidance of doubt, such rejection will be treated as non-submission of the LC where such LC is required in the Tender.*
2. *It is the responsibility of the Tenderer to sensitize its issuing bank on the need to respond directly and expeditiously to any queries from KPLC. The period for response shall not exceed three (3) days from the date of KPLC's query. Should there be no conclusive response by the Bank within this period, such Tenderer's Tender Security shall be deemed as invalid and the bid rejected.*
3. ***The issuing bank should address its response or communication regarding the bond to KPLC at the following e-mail address – “[guarantees@ kplc.co.ke](mailto:guarantees@kplc.co.ke)”***
4. *The Tender validity period is ninety (90) days as set out in the Invitation to Tender (at Section I of the Tender document) or as otherwise may be extended by KPLC. Therefore the Tender Security must at all times be valid for at least 30 days beyond the tender validity period.*
5. *All Guarantees issued by foreign banks must be confirmed by a local bank in Kenya.*

SECTION XIII - MANUFACTURER'S AUTHORIZATION FORM

(To Be Submitted On Manufacturer's Letterhead)

To:

The Kenya Power & Lighting Company Limited,
Stima Plaza, Kolobot Road, Parklands,
P.O Box 30099 – 00100,
Nairobi, Kenya.

WHEREAS WE (*name of the manufacturer*) who are established and reputable manufacturers of (*name and description of the goods*) having factories at (*full address and physical location of factory(ies) where goods to be supplied are manufactured*) do hereby confirm that (*name and address of Supplier*) is authorized by us to transact in the goods required against your Tender (*insert reference number and name of the Tender*) in respect of the above goods manufactured by us.

DATED THIS..... DAY OF20.....

Signature of duly authorised person for and on behalf of the Manufacturer.

Name and Designation of duly authorised person signing on behalf of the Manufacturer

NOTES TO TENDERERS AND MANUFACTURERS

Only a competent person in the service of the Manufacturer should sign this letter of authority.

SECTION XIIB - MANUFACTURER’S WARRANTY FORM

To Be Submitted On Manufacturer’s Letterhead)

To:

The Kenya Power & Lighting Company Limited,
Stima Plaza, Kolobot Road, Parklands,
P.O Box 30099 – 00100,
Nairobi, Kenya.

**RE: MANUFACTURER’S WARRANTY FOR GOODS REQUIRED UNDER
TENDER NO TO BE SUPPLIED BY
.....(indicate your name or the supplier you have authorized)**

WE HEREBY WARRANT THAT:

- a) The goods to be supplied under the contract are new, unused, of the most recent or current specification and incorporate all recent improvements in design and materials unless provided otherwise in the Tender.
- b) The goods in the Tenderer’s bid have no defect arising from manufacture, materials or workmanship or from any act or omission of the Tenderer that may develop under normal use of the goods under the conditions obtaining in Kenya.

The Warranty will remain valid One (1) year after the goods, or any portion thereof as the case may be, have been delivered to the final destination indicated in the contract.

DATED THIS..... DAY OF 20.....

Signature of duly authorised person for and on behalf of the Manufacturer.

Name and Designation of duly authorised person signing on behalf of the Manufacturer

NOTES TO TENDERERS AND MANUFACTURERS

- 1. *Only a competent person in the service of the Manufacturer should sign this letter of authority.*
- 2. *Provide full contact details including physical address, e-mail, telephone numbers and the website on the Warranty.*

SECTION XIII - DECLARATION FORM

Date _____

To:

The Kenya Power & Lighting Company Limited,
P.O Box 30099 – 00100,
Stima Plaza, Kolobot Road, Parklands,
Nairobi,
KENYA.

Ladies and Gentlemen,

The Tenderer i.e. (full name and complete physical and postal address) _____
_____ declare the following: -

- a) That I/ We have not been debarred from participating in public procurement by anybody, institution or person.
- b) That I/ We have not been involved in and will not be involved in corrupt and fraudulent practices regarding public procurement anywhere.
- c) That I/We or any director of the firm or company is not a person within the meaning of paragraph 3.2.3 and 3.2.4 of ITT (Eligible Tenderers) of the Instruction to Tenderers.
- d) That I/ We are not insolvent, in receivership, bankrupt or in the process of being wound up and is not the subject of legal proceedings relating to the foregoing.
- e) That I/We do hereby confirm that all the information given in this tender is accurate, factual and true to the best of our knowledge.
- f) That I/ We are not associated with any other Tenderer participating in this tender.

Yours sincerely,

Name of Tenderer

Signature of duly authorised person signing the Tender

Name and Designation of duly authorised person signing the Tender

Stamp or Seal of Tenderer

SECTION XIV – DRAFT LETTER OF NOTIFICATION OF AWARD

To: *(Name and full address of the Successful Tenderer)*

Date:.....

Dear Sirs/ Madams,

RE: NOTIFICATION OF AWARD OF TENDER NO.

We refer to your Tender dated..... and are pleased to inform you that following evaluation, your Tender has been accepted as follows: -

.....
.....

This notification does not constitute a contract. The formal Contract Agreement, which is enclosed herewith shall be entered into upon expiry of fourteen (14) days from the date hereof pursuant to the provisions of the Public Procurement and Asset Disposal Act, 2015 *(or as may be amended from time to time or replaced)*.

Kindly sign, and seal the Contract Agreement. Further, initial and stamp on all pages of the documents forming the Contract that are forwarded to you with this letter. Thereafter return the signed and sealed Contract together with the documents to us within fourteen (14) days of the date hereof for our further action.

We take this opportunity to remind you to again note and strictly comply with the provisions as regards the Tender Security, Signing of Contract and Performance Security as stated in the Instructions to Tenderers.

We look forward to a cordial and mutually beneficial business relationship.

Yours faithfully,

FOR: THE KENYA POWER & LIGHTING COMPANY LIMITED

GENERAL MANAGER, SUPPLY CHAIN

Enclosures

SECTION XV – DRAFT LETTER OF NOTIFICATION OF REGRET

To: *(Name and full address of the Unsuccessful Tenderer)* **Date:**

Dear Sirs/ Madams,

RE: NOTIFICATION OF REGRET IN RESPECT OF TENDER NO.

We refer to your Tender dated..... and regret to inform you that following evaluation, your Tender is unsuccessful. It is therefore not accepted. The brief reasons are as follows:-

1.
2.
- 3 etc...

The successful bidder was_____.

However, this notification does not reduce the validity period of your Tender Security. In this regard, we request you to relook at the provisions regarding the Tender Security, Signing of Contract and Performance Security as stated in the Instructions to Tenderers.

You may collect the tender security from our *Legal Department (Guarantees Section), on the 2nd Floor, Stima Plaza, Kolobot Road, Parklands, Nairobi* only after expiry of twenty five (25) days from the date hereof on Mondays and Wednesdays ONLY between 9.00 a.m to 12.30 pm and 2.00p.m to 4.00p.m.

It is expected that by that time KPLC and the successful bidder will have entered into a contract pursuant to the Public Procurement and Asset Disposal Act, 2015 *(or as may be amended from time to time or replaced)*. When collecting the Security, you will be required to produce the original or certified copy of this letter.

We thank you for the interest shown in participating in this tender and wish you well in all your future endeavours.

Yours faithfully,

FOR: THE KENYA POWER & LIGHTING COMPANY LIMITED

GENERAL MANAGER, SUPPLY CHAIN

SECTION XVI - CONTRACT AGREEMENT FORM

THIS AGREEMENT made this.....day of.....20.... **BETWEEN THE KENYA POWER & LIGHTING COMPANY LIMITED**, a limited liability company duly incorporated under the Companies Act, Chapter 486 of the Laws of Kenya, with its registered office situated at Stima Plaza, Kolobot Road, Parklands, Nairobi in the Republic of Kenya and of Post Office Box Number 30099-00100, Nairobi in the Republic aforesaid (*hereinafter referred to as the "KPLC"*) of the one part,

AND

..... (*Supplier's full name and principal place of business*) a duly registered entity according to the laws of..... (*state country*) and of Post Office Box Number/Physical Address.....(*full address of Supplier*) in the Republic aforesaid, (*hereinafter referred to as the "Supplier"*) of the other part;

WHEREAS KPLC invited tenders for certain goods, that is to say for(*KPLC Supply Chain – Procurement Department insert description of goods*) under Tender Number..... (*KPLC Supply Chain – Procurement Department insert tender number*)

AND WHEREAS KPLC has accepted the Tender by the Supplier for the goods in the sum of(*KPLC Supply Chain – Procurement Department specify the total amount in words which should include any payable taxes, duties and insurance where applicable e.g. Value Added Tax*) (*hereinafter called "the Contract Price"*).

NOW THIS AGREEMENT WITNESSETH AS FOLLOWS: -

1. In this Agreement words and expressions shall have the same meanings as are respectively assigned to them in the Conditions of Contract and the Tender Document.
2. Unless the context or express provision otherwise requires: -
 - a) reference to "this Agreement" includes its recitals, any schedules and documents mentioned hereunder and any reference to this Agreement or to any other document includes a reference to the other document as varied supplemented and or replaced in any manner from time to time.
 - b) any reference to any Act shall include any statutory extension, amendment, modification, re-amendment or replacement of such Act and any rule, regulation or order made there-under.
 - c) words importing the masculine gender only, include the feminine gender or (as the case may be) the neutral gender.

- d) words importing the singular number only include the plural number and vice-versa and where there are two or more persons included in the expression the “*Supplier*” the covenants, agreements obligations expressed to be made or performed by the Supplier shall be deemed to be made or performed by such persons jointly and severally.
 - e) Where there are two or more persons included in the expression the “*Supplier*” any act default or omission by the Supplier shall be deemed to be an act default or omission by any one or more of such persons.
3. In consideration of the payment to be made by KPLC to the Supplier as hereinafter mentioned, the Supplier hereby covenants with KPLC to supply the goods and remedy any defects thereon in conformity in all respects with the provisions of the Contract.
 4. KPLC hereby covenants to pay the Supplier in consideration of the proper supply of the goods and the remedying of defects therein, the Contract Price or such other sum as may become payable under the provisions of the Contract at the times and in the manner prescribed by the Contract.
 5. The following documents shall constitute the Contract between KPLC and the Supplier and each shall be read and construed as an integral part of the Contract: -
 - a) this Contract Agreement
 - b) the Special Conditions of Contract as per the Tender Document
 - c) the General Conditions of Contract as per the Tender Document
 - d) the Price Schedules submitted by the Supplier and agreed upon with KPLC
 - e) the Technical Specifications as per KPLC’s Tender Document
 - f) the Schedule of Requirements
 - g) KPLC’s Notification of Award dated.....
 - h) the Tender Form signed by the Supplier
 - i) the Declaration Form signed by the Supplier/ successful Tenderer
 - j) the Warranty

- k) the Delivery Schedule
6. In the event of any ambiguity or conflict between the contract documents listed above, the order of precedence shall be the order in which the contract documents are listed in 5 above except where otherwise mutually agreed in writing.
 7. The Commencement Date shall be the working day immediately following the fulfillment of all the following: -
 - a) Execution of this Contract Agreement by KPLC and the Supplier.
 - b) Issuance of the Performance Bond by the Supplier and confirmation of its authenticity by KPLC.
 - c) Issuance of the Official Order by KPLC to the Supplier.
 - d) Where applicable, Opening of the Letter of Credit by KPLC.
 8. The period of contract validity shall begin from the Commencement date and end on -
 - a) sixty (60) days after the last date of the agreed delivery schedule, or,
 - b) where a Letter of Credit is adopted as a method of payment, sixty (60) days after the expiry date of the Letter of Credit or the expiry date of the last of any such opened Letter of Credit whichever is later.

Provided that the expiry period of the Warranty shall be as prescribed and further provided that the Warranty shall survive the expiry of the contract.
 9. It shall be the responsibility of the Supplier to ensure that its Performance Security is valid at all times during the period of contract validity and further is in the full amount as contracted.
 10. Any amendment, change, addition, deletion or variation howsoever to this Contract shall only be valid and effective where expressed in writing and signed by both parties.
 11. No failure or delay to exercise any power, right or remedy by KPLC shall operate as a waiver of that right, power or remedy and no single or partial exercise of any other right, power or remedy shall operate as a complete waiver of that other right, power or remedy.
 12. Notwithstanding proper completion of delivery or parts thereof, all the provisions of this Contract shall continue in full force and effect to the extent that any of them remain to be implemented or performed unless otherwise expressly agreed upon by both parties.

13. Any notice required to be given in writing to any Party herein shall be deemed to have been sufficiently served, if where delivered personally, one day after such delivery; notices by electronic mail shall be deemed to be served one day after the date of such transmission and delivery respectively (*and proof of service shall be by way of confirmation report of such transmission and or delivery*), notices sent by post shall be deemed served seven (7) days after posting by registered post (*and proof of posting shall be proof of service*), notices sent by courier shall be deemed served two (2) days after such receipt by the courier service for Local (Kenyan) Suppliers and five (5) days for Foreign Suppliers.

14. For the purposes of Notices, the address of KPLC shall be Company Secretary, The Kenya Power & Lighting Company Limited, 7th Floor, Stima Plaza, Kolobot Road, Post Office Box Number 30099–00100, Nairobi, Kenya. The address for the Supplier shall be the Supplier’s address as stated by it in the Confidential Business Questionnaire provided in the Tender Document.

IN WITNESS whereof the parties hereto have caused this Agreement to be executed in accordance with the laws of Kenya the day and year first above written.

SIGNED FOR and on **BEHALF**
of **KPLC**

MANAGING DIRECTOR & CEO

and in the presence of:-

COMPANY SECRETARY

SEALED with the **COMMON SEAL**
of the **SUPPLIER**
in the presence of:-

DIRECTOR

Affix Supplier’s Seal here

DIRECTOR’S FULL NAMES

and in the presence of:-

DIRECTOR/ COMPANY SECRETARY

DIRECTOR/ COMPANY SECRETARY'S FULL NAMES

*OR

SIGNED BY and on **BEHALF**
of the **SUPPLIER**

SIGNATURE OF THE SUPPLIER

FULL NAMES OF THE SUPPLIER

***NOTES TO THE SUPPLIER**

1. *Please note that the alternative is applicable IF AND ONLY IF the Supplier is not a registered company but has tendered, and, is trading as a sole proprietor or a partnership as provided in the Confidential Business Questionnaire or is registered as a business name.*
2. *In all other cases, the Supplier is required to execute the contract as first provided.*

DRAWN BY: -

Awuor Owiti,

Advocate,

C/o The Kenya Power & Lighting Company Limited,

7th Floor, Stima Plaza,

Kolobot Road, Parklands,

Post Office Box Number 30099-00100,

NAIROBI, KENYA,

Telephones: + 254-20-3201000/ 731

SECTION XVII A - PERFORMANCE SECURITY FORM (BANK GUARANTEE)

(To Be Submitted On Bank’s Letterhead)

Date:

To:

The Kenya Power & Lighting Company Limited,
Stima Plaza,
Kolobot Road, Parklands,
P.O Box 30099 – 00100,
Nairobi, Kenya.

WHEREAS.....(hereinafter called “the Supplier”) has undertaken, in pursuance of your Tender Number.....(*reference number of the Tender*) and its Tender dated(*insert Supplier’s date of Tender taken from the Tender Form*) to supply(*description of the goods*) (hereinafter called “the Contract);

AND WHEREAS it has been stipulated by you in the said Contract that the Supplier shall furnish you with a bank guarantee by an acceptable bank for the sum specified therein as security for compliance of the Supplier’s performance obligations in accordance with the Contract;

AND WHEREAS we have agreed to give the Supplier a guarantee;

THEREFORE WE HEREBY AFFIRM that we are Guarantors and responsible to you, on behalf of the Supplier, up to a total sum of..... (*amount of the guarantee in words and figures*) and we undertake to pay you, upon your first written demand declaring the Supplier to be in default under the Contract and without cavil or argument, any sum or sums within the limits of (*amount of guarantee*) as aforesaid, without you needing to prove or to show grounds or reasons for your demand or the sum specified therein.

This guarantee is valid until theday of... 20....

EITHER

SEALED with the)
COMMON SEAL)
of the said **BANK**)
)

thisday) _____
) BANK SEAL
 of20....)
 in the presence of :-)
)
 _____)
)
 and in the presence of:-)
)
 _____)

OR

SIGNED by the **DULY AUTHORISED**
REPRESENTATIVE(S)/ ATTORNEY(S) of
 the **BANK**

 Name(s) and Designation of duly authorised representative(s)/ attorney(s) of the Bank

 Signature(s) of the duly authorised person(s)

NOTES TO SUPPLIERS AND BANKS

1. *Please note that no material additions, deletions or alterations regarding the contents of this Form shall be made to the Performance Security Bond (the Bond) to be furnished by the successful Tenderer/ Supplier. If any are made, the Bond may not be accepted and shall be rejected by KPLC. For the avoidance of doubt, such rejection will be treated as non-submission of the Bond where such Bond is required in the tender and Contract.*

2. *KPLC shall seek authentication of the Performance Security from the issuing bank. It is the responsibility of the Supplier to sensitize its issuing bank on the need to respond directly and expeditiously to queries from KPLC. The period for response shall not exceed three (3) days from the date of KPLC's query. Should there be no conclusive response by the Bank within this period, such Supplier's Performance Security may be deemed as invalid and the Contract nullified.*

3. *The issuing Bank should address its response or communication regarding the bond to KPLC at the following e-mail address – “[guarantees@ kplc.co.ke](mailto:guarantees@kplc.co.ke)”*

SECTION XVII B - PERFORMANCE SECURITY (LC)

Mandatory Conditions that should appear on the Performance Security (LC).

Form of Documentary credit - “Irrevocable Standby”

Applicable rules - “Must be UCP Latest Version” i.e. UCP 600 (2007 REVISION) ICC Publication No. 600.

Place of expiry - At the counters of the advising bank.

The SBLC should be available – “By Payment”

Drafts should be payable at - “SIGHT”

Documents required -

1. Beneficiary’s signed and dated statement demanding for payment under the letter of credit no..... *(Insert LC No.)* as.....*(Name of Applicant)* (hereinafter called the “Supplier”) indicating that the “Supplier” has defaulted in the performance and adherence to and performance of the contract between the Beneficiary and the Supplier.
2. The Original Letter of Credit and all amendments, if any.

Additional Conditions -

1. All charges levied by any bank that is party to this documentary credit are for the account of the Applicant.
2. (Include) that there should be no conditions requiring compliance with the specific regulations or a particular country’s laws and regulations.

Charges - All bank charges are for the account of the Applicant.

Confirmation instructions – (See notes below)

NOTES TO SUPPLIERS AND BANKS

1. *Please note that should the Performance Security (LC) omit any of the above conditions the LC shall not be accepted and shall be rejected by KPLC. For the avoidance of doubt, such rejection will be treated as non-submission of the LC where such LC is required in the tender and Contract.*
2. *KPLC may seek authentication of the Performance Security (LC) from the issuing*

bank. It is the responsibility of the Supplier to sensitize its issuing bank on the need to respond directly and expeditiously to queries from KPLC. The period for response shall not exceed three (3) days from the date of KPLC's query. Should there be no conclusive response by the Bank within this period, such Supplier's Performance Security (LC) may be deemed as invalid and the Contract nullified.

- 3. *The issuing bank should address its response or communication regarding the bond to KPLC at the following e-mail address – “guarantees@kplc.co.ke”***
- 4. *All Guarantees issued by foreign banks must be confirmed by a local bank in Kenya.***

**SECTION XVIII – SUBCONTRACTORS
(INFORMATION TO BE PROVIDED BY THE TENDERER)**

As per the requirements of Clause 7.23 of General Conditions of Contract, following is a list of subcontractors and the portions of the Work to be subcontracted:

No.	Subcontractor	Address	Brief Description of the Works to be Subcontracted	% works subcontracted

**SECTION XIX - PREVIOUS EXPERIENCE WITH SIMILAR WORK
(INFORMATION TO BE PROVIDED BY THE TENDERER)**

As required by Section 3.13.3(d) of the Instructions To Tenderers, following is a list of work that the Tenderer has previously performed which is similar to that described in the Request for Proposal:

No.	Description	Customer Name & Contacts	Date of Supply

SECTION XVIII - SUPPLIER EVALUATION FORM

(This form is for information only and not to be filled in by any bidder. It is for official use by KPLC to evaluate performance of Suppliers during the contract period)

Name of Firm.....Date..... Category of Product/Service (e.g. Conductors Period of evaluation.....

1. COST OF SERVICE/PRODUCT	Rating guidelines				Supplier Score	Procurement Score	User Score	Comments	Totals
	Did the vendor assist in or advice on ways of reducing the costs?	YES:4	PARTIALLY:2	NO: 0					10
	How closely did your final costs correspond to your expectation at the beginning of the project/tender?	YES:2	PARTIALLY:1	NO: 0					10.00%
	Did the company stick to the agreed transaction/contract rates?	YES:4	PARTIALLY:2	NO: 0					
2.ON TIME DELIVERY OF PRODUCT OR SERVICE									Totals
	Did the vendor perform work in compliance with contract terms and agreements?	YES:6	PARTIALLY:3	NO: 0					10
	Was the vendor prompt and effective in correction of situations and conditions?	YES:2	PARTIALLY:1	NO: 0					10.00%
	Are you able to track service level agreements and determine duration of incidents from the vendor?	YES:2	PARTIALLY:1	NO: 0					
3.FLEXIBILITY TO RESPOND TO UNEXPECTED DEMAND OF SERVICE									Totals
	Was the vendor willing to change their product/service on special needs?	YES:6	PARTIALLY:3	NO: 0					6
									6.00%
4. QUALITY									Totals
	When performing their duties, was there - rework or returns caused by non-conformance to quality?	NO:6	PARTIALLY:3	YES: 0					14
	Was the quality of service delivered equal to KPLC minimum requirements?	YES:8	PARTIALLY:4	NO: 0					14.00%
5.RESPONSIVENESS									Totals
	Was the vendor well responsive to information requests, issues, or problems that arose in the course of service?	YES:2	PARTIALLY:1	NO: 0					14
	Was the vendor open to feedback on low quality of service levels and willing to act on this?	YES:6	PARTIALLY:3	NO: 0					14.00%
	Is it easy to reach staff members of suppliers in case of a request or query? (Are communication channels clear?)	YES:6	PARTIALLY:3	NO: 0					
6. CUSTOMER SUPPORT									Totals
	Rating guidelines								

	Did the vendor offer effective customer support?	YES:10	PARTIALLY:4	NO: 0					18
	In case of reported problems/issues, were there	YES:8	PARTIALLY:4	NO: 0					18.00%
	follow ups by the vendor to ensure the problem is fully resolved during support?								
7. COMMUNICATION SKILLS	Rating guidelines								Totals
	Are you satisfied with the attitude, courtesy, and professionalism of this vendor's staff? Written or spoken?	YES:2	PARTIALLY:1	NO: 0					6
	Are the vendor's staff well equipped and skilled in handling requests/issues? Are you rotated too much among staff on an issue?	YES:4	PARTIALLY:2	NO: 0					6.00%
8. DOCUMENTATION AND ACCOUNTING	Rating guidelines								Totals
	Are you satisfied with how the Vendor presents documentation (invoices & licenses etc) when required to do so, to necessitate finalization of contract renewals and payments?	YES:6	PARTIALLY:3	NO: 0					10
	Was problem documentation (incident reports) presented promptly by the vendor and was it complete?	YES:4	PARTIALLY:2	NO: 0					10.00%
9. VALUE ADD	Rating guidelines								Totals
	Did the vendor go over and above in optimizing service delivery process for effective services delivery?	YES:6	PARTIALLY:3	NO: 0					12
	Did the vendor go over and above and offer training or knowledge to assist with better systems support?	YES:6	PARTIALLY:3	NO: 0					12.00%
									Totals
									Score:
	Totals								100.0
	Maximum Score								100.00%
	VENDOR'S TOTAL SCORE								
	VENDOR'S PERCENTAGE SCORE								
	ISSUES FOR FOLLOW UP -								
	Evaluation Done by: Name Department Date								
	Checked/Validated by								

Score in Percentage %

PERFORMANCE LEVEL DEFINATION:

- ≥75% - KP1 GREEN
- 50% - KP2 AMBER
- 25% - KP3 YELLOW
- ≥25% - KP4 RED

RATING: 75% - V Good, 50% - Good, 25% - Fair, Below 25% - Poor

RECOMMENDATION

		Status	Tick as appropriate
1	Grant supplier preferred status	KP1	
2	Work with supplier or develop and improve supplier	KP2 & KP3	
3	Abandon / switch suppliers	KP4	

Name:.....Sign:.....Date:.....

Name:.....Sign:.....Date:.....

Name:.....Sign:.....Date:.....

SECTION XIX - THE TECHNICAL SPECIFICATIONS

Technical specifications describe the basic requirements for goods. In addition to the information and documentation in the Tender Document regarding the technical aspects of this tender, all Tenderers shall comply with the following -

PART A - GENERAL REQUIREMENTS

1. Technical documentation shall be in English language. The specific items on offer shall be marked clearly for the goods they intend to supply. The type reference or model number(s) of the item(s) on offer must be clearly indicated in the bid.
2. The Tenderer shall submit the Schedule of Guaranteed Technical Particulars (GTP) completed and signed by the Manufacturer. In submitting the GTP, cross-references should be made to the documents submitted.
3. Deviations from the tender specifications, if any, shall be explained in detail in writing, with supporting data including calculation sheets, detailed drawings and certified test reports and submitted together with the Tender. In submitting the deviations, cross-references should be made to the documents submitted. KPLC reserves the right to reject the goods if such deviations shall be found critical to the use and operation of the goods.
4. Detailed contact information including title, e-mail, facsimile, telephone or any other form of acceptable communication of the testing and standards body used shall be provided.
5. Where Type Test Certificates and their Reports and or Test Certificates and their Reports are translated into English, all pages of the translations must be signed and stamped by the testing authority.
6. A Copy of the manufacturer's valid quality management system certification i.e. ISO 9001 shall be submitted for evaluation. For locally manufactured goods, valid KEBS Mark of Quality Certificate or KEBS Standardization Mark Certificate will also be accepted.
7. In all cases where the level of galvanizing and painting is not specifically stated in the detailed Technical Specifications, the general requirement shall be for a uniform coating of thickness not less than 80 microns.

8. Suppliers are required to provide information on proper representative(s) and or workshop for back-up service and or repair and maintenance including their names, telephone, facsimile, e-mail, physical and postal addresses, along with their offers

PART B – DETAILED TECHNICAL SPECIFICATIONS (DTS)

LOT 1: FIBER OPTIC CABLES, TOOLS AND INSTALLATION ACCESSORIES

1. TECHNICAL SPECIFICATIONS FOR THE FIBER OPTIC CABLE AND FIBER INSTALLATION ACCESSORIES

The fiber optic cable, installation accessories and fiber patch cords in the schedule of requirements shall conform to the minimum requirements below;

1.1. FIBER OPTIC CABLE & INSTALLATION ACCESSORIES

1.2. ADSS Fiber Optic cable 48 core single mode (9/125)

The ADSS optical cable shall be of non-metallic Aerial type designed for installation on distribution lines of 66Kv, 33Kv and 11Kv distribution lines with minimum span lengths of 100 meters. The Bidder shall offer ADSS containing 48 Nos. of Single Mode (SM) optical fibers in conformity with ITU-T recommendations G-652D. The cable shall be designed to withstand all prevailing environmental conditions including the effects of high electric and magnetic fields produced by the proximity of live power conductors and meet the requirements of International Standard IEEE P1222.

1.2.1. Mechanical and Environmental specifications for 48 core SM (9/125) ADSS fiber optic cable

The cable shall be constructed from materials which have been technically proven and able to withstand the electrical and environmental conditions.

Table 1 below gives the desired mechanical and environmental specifications for the ADSS Fiber Optic Cable for minimum performance characteristics.

Table 1 Mechanical and environmental Specifications for 48 Core SM (9/125) ADSS Fiber Optic Cable

ITEM	DESCRIPTION	MINIMUM REQUIREMENTS	TENDERER'S OFFER
1	Manufacturer's Name & Country of manufacture		
2	Type Reference/Model Number of cable offered		
3	International recommended standard adhered to	1EEstd 1222, IEC 60794-4, IEC 60793-1, IEC 60793-2, IEC 60794-1, ITU-T G.652D, EIA 492A, EIA 472A, EIA 598 or ANSI/EIA 359-A-1985, ISO 9001 and ISO 14001	
4	Maximum inductive voltage (kV) that the cable can withstand as per technical specification.	66 kV	
5	Fiber counts	48	
6	Tube count	4	
7	Maximum Operating Load	6000 N	
8	Minimum Bending Radius Installation Long Term	20xO.D. 10xO.D.	
9	Maximum. Compressive Loading	4000 N	
10	Impact Resistance	4.4 J, 3 x 2 times	
11	Twist (Torsion)	10 turns of 180° on 125xO.D.sample, both ways.	
12	Storage Temperature Range	-50° C to +50° C	
13	Operating Temperature Range	-40° C to +50° C	
14	Core Fluid Penetration	1 m sample, 1 m water head for 24 Hrs	
15	Span (Distance Between Poles)	Up to 150M	
16	Warranty	15 years	
17	UV Resistance	Excellent weathering and UV resistance	
18	Outer Cable Markings	Property of Kenya Power & Lighting Company	
19	Packing	Rolls of 4000M	
20	Length marking	Every meter	

21	Color of Cable	Black	
22	Performance	Allowed attenuation per Km for the 9/125 micron single mode fiber optic cable 1) 1310nm 0.4 dB/km 2) 1550nm 0.3 dB/km	
23	Fusion splice loss	Maximum allowed loss 0.1db	
24	Wind Speed	Minimum 20m/s	
25	Jacket	PE for ADSS Cable AT for approach cable	

Manufacturer’s Name, Signature, Stamp and Date

1.2.2. Optic Fiber Approach Cable (OFAC)

The Optical Fiber Approach Cable (OFAC) shall have all properties similar to the ADSS Fiber Optic Cable. In addition the approach cable shall be of loose buffer type Optical Fiber Approach Cable (OFAC) of 48Fibers. The fiber optic approach cable shall be entirely suitable for laying through HDPE pipe in the cable ducts and on cable trays. The cable shall comprise of a tensile strength member, fiber support/bedding structure, core wrap/bedding and over all impervious jacket. No intermediate joints shall be permitted in any run of approach cable between its two termination points. The cable sheathing shall have additives to prevent rodent attack. The fiber optic approach cable shall have a minimum outer jacket thickness of 3.0 millimeters and shall meet the following requirements.

- i. Fire retardant and no acid gas evolution.
- ii. Resistance to ultra-violet deterioration.
- iii. Anti-moisture penetration.

1.2.3. Universal Pole clamps

The Universal pole clamps shall be used for securing the ADSS Fiber Optic Cable below power lines on wooden or pre-stressed/reinforced round concrete poles. The clamps shall therefore be suitable for continuous operation outdoors in tropical areas at altitudes of up to 2200m ASL, humidity of up to 95% and average ambient temperature of 30°C with a minimum of 7°C and a maximum of 40°C in direct sunlight.

The Universal pole clamps shall be of two types; a fixed clamp type to fit poles of the range 210-240mm in diameter and an adjustable type that is designed to adapt to circular concrete poles tapering at 13mm per meter. The clamps shall be fabricated from structural steel of grade Q235 as specified in the BS 4360 or its equivalent and shall be zinc plated hot dip galvanized to give it a corrosion resistance finish in accordance with ISO 1461. The tensile strength of the Universal clamp shall not be less than 70kN. Figure 1 and Figure 2 below give sample images of the fixed size universal pole clamp and the adjustable universal pole clamps respectively.



Figure 1 Universal Pole Clamp

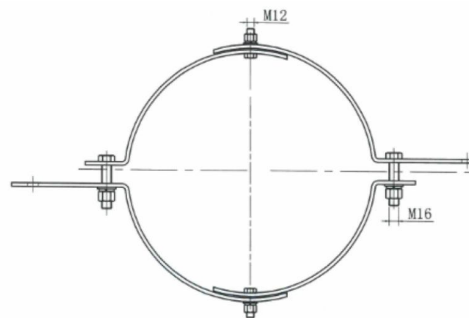

Figure 2 Adjustable Universal Pole Clamp

1.2.4. Suspension clamps

The ADSS optical cable suspension clamp unit shall be used for inline suspension of the ADSS Fiber Optic Cable. It shall provide long term performance for spans of up to 250m. It shall consist of a light Aluminum (or an Aluminum alloy) housing with rubber bushings capable of gently gripping the ADSS Fiber cable in it. The suspension clamp shall be held with a Clamping Bolt that allows the Suspension Clamp to hinge open into the rubber bushing during installation. The Aluminum housing shall be attached to an eye chain link. The Eye chain link shall in turn be attached to an anchor shackle for assembly to the Universal clamp (supplied separately). Figure 3 and Figure 4 below give illustrations of the suspension clamp fitting assembly and the suspension clamp aluminum housing respectively.

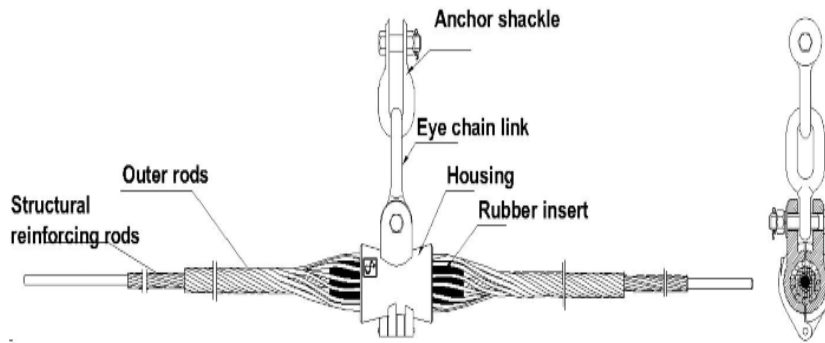

Figure 3 ADSS Suspension Fittings

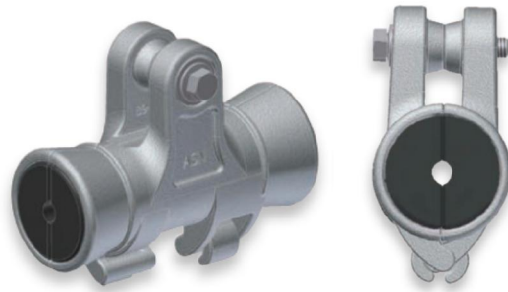

Figure 4 ADSS Suspension clamp housing showing the bushing

Table 2 below gives the desired specifications for the suspension clamp for minimum performance characteristics.

Table 2 Minimum requirements for Suspension clamp set

ITEM	DESCRIPTION	MINIMUM REQUIREMENTS	TENDERER'S OFFER
1.	Span Length Rating	250 meters	
2.	Vertical Load Rating	2.25Tonnes	
3.	Torque Requirement	Mounting bolt should be tightened to 35Nm	
4.	Mounting Hardware	5/8" eye chain link and anchor shackle shall be included in the assembly	
5.	Line Angle	Max line angle of 30 degrees	
6.	Slip Strength	6% to 10% of Recommended breaking Strength of the ADSS Fiber Optic Cable	
7.	Bushing Color	Black	

1.2.5. Tension clamp

The tension clamp shall be used for suspension of the ADSS Fiber Optic Cable in tension at cable sections, acute turnings or at the terminal pole. It shall consist of an anchor, a shackle, thimble and galvanized pre-formed guy grip of suitable length as shown in Figure 5 below. It shall be made of materials similar to the suspension clamp.



Figure 5 Tension Clamp/Dead End assembly

1.2.6. Protection rod

The protection rod or armor rod shall be designed to protect the OFC by reducing bending, compression, and abrasion at the support points. It shall be made of suitable aluminum-based material that is capable for use on ADSS OFC as shown in Figure 6 below.

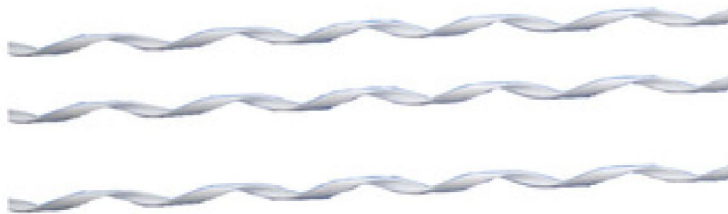

Figure 6 Protection or Armor rod

1.2.7. Preformed Guy grips

The preformed guy grip is intended for use together with the tension clamp to provide tension breaks at regular intervals on the Fiber Optic cable route. It shall be made of suitable aluminum-based material that is capable for use on ADSS OFC. Sample preformed guy grip is shown in Figure 7 below.



Figure 7 Preformed Guy grip

1.2.8. Aeolian Vibration Dampers

The Aeolian Vibration Dampers shall have a helically formed damping section sized for interplay of damper and cable to provide the action/reaction motion that opposes the natural vibration wave. It shall have a smaller gripping section that gently grips the cable so that cable and fiber are not damaged or distorted and there is no optical signal loss. They shall be made of PVC Spirals suitable for use with the ADSS Fiber Optic cable. A sample of the Aeolian vibration damper is shown in Figure 8



Figure 8 Aeolian Vibration Damper

1.2.9. Transformer by-pass Arms (Extension Arms)

The fiber glass extension arm shall be used to extend the ADSS fiber cable away from the pole line in instances where the pole carries power infrastructure that may interfere with the ADSS cable such as Air break switches, transformers and the like. Extension arm shall consist of base and end fittings that are made of aluminum alloy. The base and end fittings shall be connected using a fiber glass ferule that is tapered at 15° from the horizontal plane. The overall horizontal length shall be 91.4cm. A sample impression of the fiber glass extension arm is shown in Figure 9 below.



Figure 9 Fiberglass Extension arm

1.2.10. 4-way Splice Box - Plastic

The 4-way splice box shall be used for establishing joints in the ADSS Fiber Optic Cable. It shall be of the vertical type and shall provide for a minimum of 96 fiber terminations. It shall be of plastic material suitable for use in aerial, direct buried and/or underground cable joints. It shall provide a minimum of 4 cable out ports. Table 3 below gives a summary of the minimum requirements for the 4-way plastic splice box while Figure 10 shows a sample of the vertical plastic splice box complete with pole affixture.

Table 3 Minimum requirements for 4-way plastic splice box

ITEM	DESCRIPTION	MINIMUM REQUIREMENTS	TENDERER'S OFFER
1.	Construction	Dome	
2.	Minimum cable out ports	4	
3.	Minimum fiber capacity	96 cores	
4.	Size	400x140mm	
5.	Material	PC Plastic	
6.	Sealing structure	Waterproof screw mechanical seal	
7.	Working Temperature	-40°C to 65°C	
8.	Relative humidity	Up to 85%	
9.	Application	Aerial, Direct buried, underground	
10.	Pole affixture	Adjustable pole mounting clips minimum diameter 210-240mm	

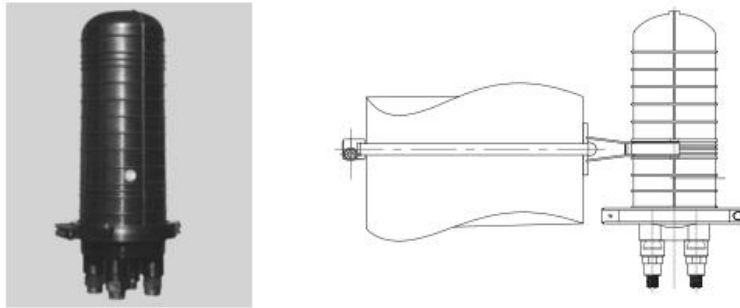

Figure 10 Plastic Splice/Joint Box

1.2.11. FOC Storage Kit

The Fiber Optic cable (FOC) storage kit shall be used to manage the cable slack on the pole. It shall be made of same material as the universal pole clamps and shall be fabricated in the form of a cross arm and provided with suitable method to affix on the pole. The FOC storage kit shall have a minimum loop diameter of 2.5ft. The kit shall be supplied complete with the appropriate pole mounting straps to allow for mounting on the pole as illustrated in Figure 11 below.

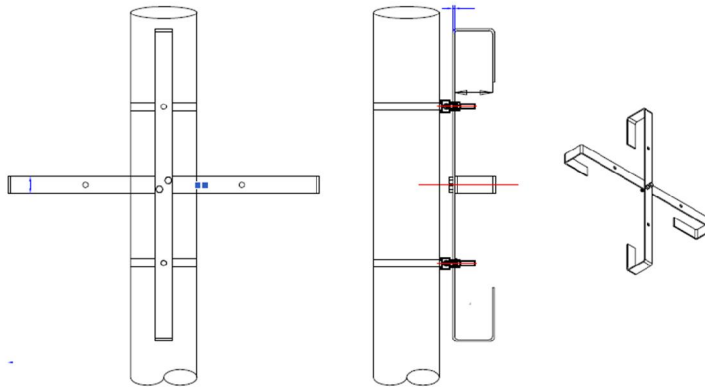

Figure 11 FOC Storage Kit Assembly

1.2.12. General Specifications for 48-Port Rack Mount Optical Distribution Frame (ODF)

This shall be a 48 port, 19" 1U Rack Mountable Optical Distribution Frame (ODF). It shall be used for the termination of the Fibers within a wall mounted or floor standing rack cabinet. The ODF shall be designed to provide protection for fiber splicing of pre-connectorized pigtailed and to accommodate connectorized termination and coupling of the fiber cables. It shall be supplied complete with 48 port patch panel, SM pigtailed with SC connectors, splice tray cassettes, splice sleeves and cable glands.



Figure 12 Rack mount Optical Distribution Frame (ODF)

1.3. FIBER OPTIC CABLE SPLICING ACCESSORIES

1.3.1. Splice Protection Heat Shrinkable sleeve

The Splice protection heat Shrinkable sleeves shall be of High Quality with OD=3.0 and L=60mm Fiber Optic Fusion Splice Sleeves Heat Shrink Tubes packaged in 100pcs per packet.

1.3.2. Self-fusing cable jointing tape

The cable jointing tape shall be composed of self-fusing, inorganic silicone rubber with an easy-tearing and easy-stripping polyester liner. The tape must be capable for continuous operation outdoors in tropical areas at altitudes of up to 2200m ASL, humidity of up to 95% and average ambient temperature of 30°C with a minimum of 7°C and a maximum of 40°C in direct sunlight. The tape must be compatible with all synthetic cable insulations as well as cable splicing compounds.

1.4. FIBER OPTIC CABLE MAINTENANCE EQUIPMENT

1.4.1. Portable Tent

This shall be a seven (7) foot tall pop up umbrella frame system with a UV resistant waterproof canvas or polyester material. It shall be of enough room to accommodate at least four (4) people, a table and four (4) chairs. It shall come with a mechanism to secure it on the ground that will prevent it from being carried away by wind. Table 4 below gives a summary of the minimum requirements for the portable tent.

Table 4 Minimum requirements for Portable tent

ITEM	DESCRIPTION	MINIMUM REQUIREMENTS	TENDERER'S OFFER
1.	Minimum number of sides	4	

ITEM	DESCRIPTION	MINIMUM REQUIREMENTS	TENDERER'S OFFER
2.	Frame construction	pop up umbrella frame system with reasonably tough material for use in rugged terrain and in tough environmental conditions	
3.	Wall material	UV Stable Canvas/polyester material	
4.	Weight	<10kg	
5.	Maximum height	7ft	
6.	Inside room	Enough to accommodate at least four (4) people, a table and four (4) chairs	

1.4.2. Portable chair

This shall be a foldable and easily portable chair. Table 5 below gives a summary of the minimum requirements for the portable chair which is also illustrated in Figure 13.

Table 5 Minimum requirements for Portable Chair

ITEM	DESCRIPTION	MINIMUM REQUIREMENTS	TENDERER'S OFFER
1.	Seat & back rest Material	Plastic	
2.	Frame structure	Tubular Steel	
3.	Side support	Steel Frame Supports	
4.	Coating	Rust proof Coated Frame Finish	
5.	Folded Size	19.25"W x 6.5"D x 42"H	
6.	Minimum carrying capacity	150kg	



Figure 13 Foldable portable chair

1.4.3. Portable table

This shall be a foldable table, light weight in design but also sturdy. It shall be capable of quick set up and fast dismantling to fit into an easy carrying bag. The table shall have a smooth surface that can be cleaned easily. Should have four sturdy legs made of heavy gauge aluminum frame and fixed with non-skid rubber feet. Table 6 below gives a summary of the minimum requirements for the portable table.

Table 6 Minimum requirements for Portable Table

ITEM	DESCRIPTION	MINIMUM REQUIREMENTS	TENDERER'S OFFER
1.	Frame material	Aluminum	
2.	size (LxWxH)	69.5cmx68.5cmx68.5cm	
3.	Carrying material	Bag	
4.	Table surface finish	water-resistant aluminum roll-up top	
5.	Construction	Foldable and easily portable	

1.4.4. Portable Diesel Generator

This shall be a portable, lightweight diesel generator with the following technical characteristics.

Table 7 Minimum requirements for Portable Diesel Generator

ITEM	DESCRIPTION	MINIMUM REQUIREMENTS	TENDERER'S OFFER
1.	MODEL	Tenderer to state	
2.	ENGINE TYPE	4-stroke, single cylinder, air cooled, gasoline	
3.	IGNITION SYSTEM	Transistor magneto	
4.	STARTING	Switch	
5.	FUEL TANK CAPACITY	6 Litters	
6.	CONTINUOUS OPERATION DURATION	9hrs	
7.	MAXIMUM OPERATING NOISE LEVEL	60 dB	
8.	FREQUENCY	50 Hz	
9.	VOLTAGE	220 V	
10.	MAX. AC OUTPUT	850 VA	
11.	RATED AC OUTPUT	750 VA	
12.	PHASE	Monophase	
13.	DIMENSIONS (L x W x H)	442x330x410 mm	
14.	DRY WEIGHT	28kg	

1.4.5. Cordless Hand Held Drill & Kit

The drill shall be a portable, battery powered, lightweight hand held tool that is capable of being used without being directly connected to a power sourcing using a cord. It shall be fitted with a hammer function that allows it to be used for making holes in wood, steel, non-ferrous metals, concrete, drywall as well as on plastics. The drill shall be supplied complete with its kit comprising battery charger, tool case and drill bits. Table 8 below gives the minimum requirements for the cordless handheld drill and the drill bits.

Table 8 Minimum requirements for Cordless Hand Held Drill

ITEM	DESCRIPTION	MINIMUM REQUIREMENTS	TENDERER'S OFFER
1.	Model	Tenderer to state	
2.	Motor type	Brushless	
3.	Power	18V Lithium-ion with integrated battery charger level indicator	
4.	Battery Size	4.0Ah	
5.	Battery Charge time	40 minutes	
6.	Chuck size	1/2inch	
7.	Torque	520lb	
8.	Tool case	Rugged plastic material suitable for protecting the drill from tough work environment	
9.	Drill bits	40 piece set compatible with 1/2inch drill	
10.	Drill bit performance	Contractor Grade Impact Drill-Driver Compatible	
11.	Drill bit durability	Made from S2 modified steel, and heat treated corrosion resistant Black Oxide coated finish	
12.	Drill bit packaging	Durable, compact storage case	

LOT 2: INTEGRATED SERVICES ROUTERS, WAN INTERFACE CARDS, SFP MODULES, PATCH CORDS AND MAINTENANCE LAPTOP.

The Integrated Services router, WAN interface cards, SFP modules, Patch cords, and Maintenance laptops in the schedule of requirements shall conform to the minimum requirements below;

2.1. INTEGRATED SERVICES ROUTER, WAN INTERFACE CARDS, SFP MODULES AND LAPTOP DETAILED SPECIFICATIONS

ITEM No.	DESCRIPTION	MINIMUM REQUIREMENTS	TENDERER'S OFFER
1	Cisco ISR 4431 Router	Cisco 4431 integrated services router 3 Network interface Modules (NIM) slots 4 WAN or LAN ports- 10/100/1000 ports 4 SFP based ports 4 RJ-45 based ports 8 GB Flash Memory 2 GB DRAM -Data plane 4GB DRAM – Control plane 500Mbps aggregate throughput 1 USB console port 1 Serial Console port- RJ45 Dual Power supply: Primary and Secondary	

		Combination of AC & DC power supply AC input voltage 100 to 240VAC DC input voltage 48V- 60V Router Warranty: 1 year	
2	EHWIC-1GE-SFP-CU CARD	Cisco Enhanced High-Speed WAN Interface Cards Cisco Gigabit Ethernet Dual-Identity Small Form-Factor Pluggable and Copper Enhanced High-Speed WAN Interface Card	
3	SFP modules	GLC-EX-SM Cisco Compatible 1000BASE-EX SFP, 1310nm DFB, 40km over single mode fiber	
4		1000BASE-LX/LH (GLC-LH-SM) 1310nm, 10Km	
5	SFP modules Must be compatible for use in ABB FOX 615/515 Multiplexers	1000BASE-EX SFP, 1310nm, ,30km over SMF, Rx sensitivity -25dBm, Dual LC connector	
6	Single Mode Media Convertors	Single Mode Media Convertors SC, 10/100Base TX UTP, 10/100 Base FX, SC type, support upto 30Km	
7		Single Mode Media Convertors 10/100Base TX UTP,10/100 Base FX, SC type, support upto 60Km	
8	Single mode fiber patch cord	Single mode fiber patch cord LC-FC 20M	
9		Single Mode Fiber patch cord SC-SC 10M	
10		Single Mode Fiber patch cord SC-SC 20M	
11		Single mode fiber patch cord SC-LC 20m	
12		Single mode fiber patch cord SC-LC 5m	
13		Single Mode Fiber patch cord SC-SC 2m	
14		Single Mode Fiber patch cord SC-FC 10M	
15	CAT 6 UTP patch cord	CAT 6 UTP patch cord 10m	
16		CAT 6 UTP patch cord 5m	
17		CAT 6 UTP patch cord 2m	
18	Flexible conduits	25mm Flexible conduits, standard length of 30m	

19	Cable ties	Cable ties 200mmx 4.8mm	
20	Maintenance laptop	<ul style="list-style-type: none"> • Operating System: Windows 7 Professional/ Ultimate • Processor: Intel-Core i5-3360M • Memory: 4096 MB , DDR3 1600MHz; 761 MHz 10-10-10-27 timing <ul style="list-style-type: none"> • Display: 15.6 inch, 16:9, 1366 x 768 Pixel • Mainboard Intel QM77(Panther Point) • Storage:7200 rpm SATA up to 500GB • Graphics Adapter: Intel HD Graphics 4000, Core: 350-1200 MHz, Memory : 800 MHz, 8.15.10.2639 • Battery: Minimum 97 Wh Lithium-Ion • Soundcard: Intel Panther Point PCH – High Definition Audio Controller • Ports: 1 Express Card 54mm, 2 USB 2.0, 2 USB 3.0 / 3.1 Gen1, 0 Firewire, 0 Thunderbolt, 1 VGA, 1 HDMI, 0 DisplayPort, 0 S-Video, 1 Kensington Lock, 1 eSata, 1 Docking Station Port, Audio Connections: 3.5mm combo, Card Reader: 5in1 (MMC/MS/MS-PRO/SD/SDHC), 1 Fingerprint Reader • Networking:Intel 82579LM Gigabit Network Connection (10/100/1000Mbit), Intel Centrino Advanced-N 6205 (a/b/g/n), Bluetooth 1 • Optical Drive: PLDS DVD-ROM DS-8D3H • Size: (1.38 x 15.26 x 10.7 in) • Camera: Webcam, HD • Maximum Weight: 2.87 Kg • Carrying bag: Should be supplied with a leather carrying bag 	

